



# CISC - Curriculum & Instruction Steering Committee

California County Superintendents Educational Services Association

Primary Content Module

Algebra I - Linear Equations and Inequalities

## The Winning EQUATION

A HIGH QUALITY MATHEMATICS PROFESSIONAL DEVELOPMENT PROGRAM FOR TEACHERS IN GRADES 4 THROUGH ALGEBRA II

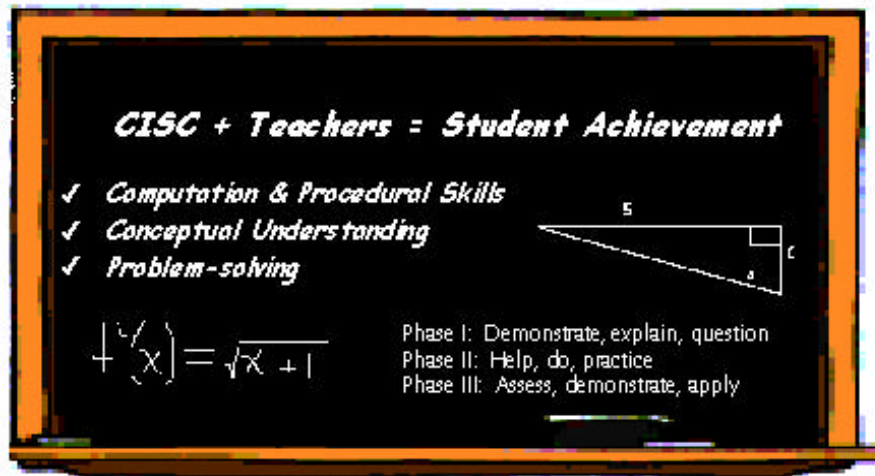

**STRAND:** Algebra I – Linear Equations and Inequalities

**MODULE TITLE:** PRIMARY CONTENT MODULE

**MODULE INTENTION:** The intention of this module is to inform and instruct participants in the underlying mathematical content in the areas of algebra and functions.

**THIS ENTIRE MODULE MUST BE COVERED IN-DEPTH.**

**The presentation of these Primary Content Modules is a departure from past professional development models. The content here, is presented for individual teacher's depth of content in mathematics. Presentation to students would, in most cases, not address the general case or proof, but focus on presentation with numerical examples.**

In addition to the underlying mathematical content provided by this module, the facilitator should use the classroom connections provided within this binder and referenced in the facilitator's notes.

**TIME:** One full day

**PARTICIPANT OUTCOMES:**

- Demonstrate understanding of the mathematics behind linear functions.
- Demonstrate understanding of the mathematics of why a graph is considered linear.
- Demonstrate how to graph linear equations and inequalities.
- Demonstrate how to deduce standard formulas.
- Demonstrate the definition of concepts through geometric arguments.



## PRIMARY CONTENT MODULE VII

**Facilitator's Notes**

NO CALCULATORS SHOULD BE USED. GRAPH PAPER IS ESSENTIAL.

**T-1  
T-2**

Ask participants to take the pre-test. Explain the rationale behind the pre-post tests. Go over the outcomes listed on transparency (T-1) of this module.

**Overview for the facilitator for this module.**

This overview is intended to help the facilitator get a sense of how the “story” of this module unfolds. Slides labeled H-xx are handouts.

**Functions and Relations**

**T-3  
to  
T-22**

The module begins with a discussion of relations and functions, including simple quadratics and cubics as examples. Practice identifying functions using the vertical line test given. Since linear functions are particular examples of functions, this serves as background information for understanding linear functions. The focus here should be on plotting points to determine the graphs of functions, and how adding a constant  $b$  to a function  $f(x)$  changes the graph. The graph of  $y = f(x) + b$  is the graph of  $y = f(x)$  translated vertically up or down, depending on  $b$ . Overhead slides T-18 through T-22 are devoted to clarifying this. This will be used to understand the role of  $b$  in the equation  $y = mx + b$  in slides that follow.

**Why is the Graph of  $y = mx$  a straight line?**

**T-23  
to  
T-34**

Background on “similarity” is given in slides T-25 and T-26. The main focus of this section begins with slide T-23. The goal is to understand why the graph of  $y = mx + b$  is necessarily a straight line. How do we know this? The approach taken here is to start with the simple case  $y = mx$ . The argument uses similar triangles and begins with slide T-28, and ends on T-30. The converse argument, that any nonvertical line through  $(0,0)$  is the graph of  $y = mx$  for some value of  $m$ , is given on T-31 and T-32. Mention to participants that we are assuming the line is not the  $x$ -axis or the  $y$ -axis. The  $x$ -axis has equation  $y = 0 \cdot x$ , so  $m = 0$ . Slide T-34 concludes this argument and exploits the result by pointing out that it is only necessary to plot two points to find the graph of  $y = mx$ , no matter what  $m$  is.



**T-35  
T-36**

### **Why is the Graph of $y = mx + b$ a straight line?**

Slides T-35 and T-36 are intended to convince the participants that the graph of  $y = mx + b$  must also be a straight line. This is because the graph of  $y = mx$  is always a straight line and adding the constant  $b$  to the function  $f(x) = mx$  just translates the graph vertically. A vertical translation of a line is still a line.

**T-37  
to  
T-44**

### **The Meaning of the Slope, $m$**

Starting with slide T-37, the goal is to understand the meaning of  $m$  in the equation  $y = mx + b$ . The approach taken here is to calculate the rise over the run determined by any two points on the graph of  $y = mx + b$  and use simple algebra to deduce that it is  $m$ . The meaning of negative slopes is also explained. The top of slide T-44 summarizes this discussion with a definition of slope.

**T-45  
T-46**

### **Further elaboration on the y-intercept and determining if a point lies on a line.**

The bottom of slide T-44 defines the y-intercept, and slides T-45 and T-46 elaborate on the meaning of the y-intercept.

**T-47  
to  
T-51**

An important goal now is to help participants learn how to find the value of the y-intercept  $b$  if they are given a point lying on the graph of  $y = mx + b$ , and if they know already the value of  $m$ . This is part of the process of determining the equation of a line from two points that lie on its graph. T-47 through T-51 guide participants through this part of the process.

**T-52  
to  
T-54**

Slides T-52 through T-54 help participants to review the main ideas covered above. They are asked to graph a line using any two points on the line. They are also asked to use the slope and y-intercept to find a graph.

**T-55  
to  
T-62**

Slide T-55 summarizes once again the Algebra I standard which requires students to determine if a point lies on the graph determined by a linear function. The same standard requires students to derive the equation of a line from two points. Guided practice follows through slide T-62.

### **Horizontal and Vertical Lines**

**T-63  
T-64**

Slide T-63 explains that horizontal lines correspond to zero slope. Slide T-64 discusses vertical lines. Vertical lines are not a special case of the slope intercept equation,  $y = mx + b$ .



**T-65  
to  
T-70**

### **The General Linear Equation**

The next step is to show that vertical and nonvertical lines are both special cases of the general linear equation,  $Ax + By = C$ . This development proceeds through slide T-70.

**T-71  
to  
T-74**

### **Parallel and Perpendicular lines**

Slides T-71 through T-74 are devoted to an important application of linear functions. Participants are guided through the derivation of the formulas for converting from the Fahrenheit to Celsius temperature scales and vice versa.

**T-75**

Slide T-75 introduces Standard 8 of the Algebra I standard which asks students to understand the concept of parallel and vertical lines and how their slopes are related.

**T-76  
to  
T-79**

Slides T-76 through T-79 explain that parallel lines have the same slope. Slide T-79 summarizes the result as a theorem and gives the corresponding theorem for perpendicular lines.

**T-80  
to  
T-84**

Slides T-80 through T-84 give practice using the theorems which characterize parallel and perpendicular lines.

**T-85  
to  
T-95**

Slides T-85 through T-95 give a proof using the Pythagorean Theorem and its converse that two nonvertical lines are perpendicular if and only if the product of their slopes is  $-1$ . The Pythagorean Theorem is explained on slide T-86 and it is then used to derive the distance formula in the plane. This formula is needed to carry out the proof of the theorem for vertical lines.

**T-90**

The converse of the Pythagorean Theorem is given on slide T-90 and the proof of the theorem relating the slopes of perpendicular lines is completed on slide T-95.

### **SAT Problem**

**T-96**

Slide T-96 has a sample problem on linear functions from the SAT for students to try. Answer: C

### **Linear Inequalities**

**T-97  
to  
T-102**

The remaining slides are devoted to linear inequalities and can be used or omitted at the facilitators discretion.

Talk about linear inequalities. For example  $y > x + 2$  and explain how to graph it.



- The first step is to graph the line. Determine two points to graph the line  $y = x + 2$ . Here it might be easy to determine where the line cuts the x and y-axis. Here the intercepts are (0,2) and (-2,0).
- Draw a dashed line as the inequality is  $>$ . If the inequality was  $<$  this is also a dashed line. The line is solid only if the inequality is  $\geq$  or  $\leq$ .
- In this case  $y > mx + b$ . Since the y-values satisfying the inequality are greater than the corresponding y-values on the line  $y = mx + b$ , it follows that half-plane above the line must be shaded. T-102 gives another example.

### Final Tasks

Provide time for participants to ask clarifying questions.

Give pre-post test.

### Standards Covered in this Module

#### Grade 3 Algebra and Functions

- 2.0 Students represent simple functional relationships.
- 2.1 Solve simple problems involving a functional relationship between two quantities (e.g., find the total cost of multiple items given by the cost per unit.)
- 2.2 Extend and recognize a linear pattern by its rules (e.g., the number of legs on a given number of horses may be calculated by counting the 4s or by multiplying the number of horses by 4).

#### Grade 4 Algebra and Functions

- 1.5 Understand that an equation such as  $y = 3x + 5$  is a prescription for determining a second number when a first number is given.
- 2.0 Students know how to manipulate equations.
- 2.1 Know and understand that equals added to equals are equal.
- 2.2 Know and understand that equals multiplied by equals are equal.

#### Grade 4 Measurement and Geometry

- 2.0 Students use two-dimensional coordinate grids to represent points and graph lines and simple figures.
- 2.1 Draw the points corresponding to linear relationships on graph paper (e.g., draw 10 points on the graph of the equation  $y = 3x$  and connect them by using a straight line).



- 2.2 Understand that the length of a horizontal line segment equals the difference of the x-coordinates.
- 2.4 Understand that the length of a vertical line segment equals the difference of the y-coordinates.
- 3.0 Students demonstrate an understanding of plane and solid geometric objects and use this knowledge to show relationships and solve problems.
- 3.1 Identify lines that are parallel and perpendicular.

### Standards Covered in this Module – 2

#### Grade 5 Algebra and Functions

- 1.0 Students use variables in simple expressions, compute the value of the expression for specific values of the variable, and plot and interpret the results.
- 1.3 Know and use the distributive property in equations and expressions with variables.
- 1.4 Identify and graph ordered pairs in the four quadrants of the coordinate plane.
- 1.5 Solve problems involving linear functions with integer values; write the equation; and graph the resulting ordered pairs of integers on a grid.

#### Grade 5 Measurement and Geometry

- 2.0 Students identify, describe, and classify the properties of, and the relationships between, plane and solid geometric figures.
- 2.1 Measure, identify, and draw angles, perpendicular and parallel lines, rectangles and triangles by using appropriate tools (e.g., straightedge, ruler, compass, protractor, drawing software).

#### Grade 6 Algebra and Functions

- 1.0 Students write verbal expressions and sentences as algebraic expressions and equations; they evaluate algebraic expressions, solve simple linear equations, and graph and interpret their results.
- 1.1 Write and solve one-step linear equations in one variable.
- 1.2 Write and evaluate an algebraic expression for a given situation, using up to three variables.

#### Grade 7 Algebra and Functions

- 3.0 Students graph and interpret linear and some nonlinear functions.
- 3.1 Graph functions of the form  $y = nx^2$  and  $y = nx^3$  and use in solving problems.



3.3 Graph linear functions, noting that the vertical change (change in y-value) per unit of horizontal change (change in x-value) is always the same and know that the ratio (“rise over run”) is called the slope of the graph.

**Standards Covered in this Module – 3**

Grade 7 Algebra and Functions

- 4.0 Students solve simple linear equations and inequalities over the rational numbers.
- 4.1 Solve two-step linear equations and inequalities in one-variable over the rational numbers, interpret the solution or solutions in the context form which they arose, and verify the reasonableness of the results.

Grade 7 Measurement and Geometry

- 3.0 Students know the Pythagorean theorem and deepen their understanding of plane and solid geometric shapes by constructing figures that meet given conditions and by identifying attributes of figures.
- 3.3 Know and understand the Pythagorean Theorem and its converse and use it to find the length of the missing side of a right triangle and the length of other line segments and, in some situations, empirically verify the Pythagorean Theorem by direct measurement.

Algebra Standards listed here by number only since all will be part of the teaching of the module.

## Pre/Post Test

- The equation of a line that has a slope of  $-2$  and a  $y$ -intercept of  $1$  is
  - $2x + 3y = 1$
  - $y = -2x + 1$
  - $y = 2x + 1$
  - $y + x = -1$
- The equation of the line that goes through  $(1,2)$  and is parallel to  $y = 3x + 1$  is
  - $y = 3x + 2$
  - $3x - y = 1$
  - $x = 3y + 1$
  - $3xy = 1$
- The slope of a line perpendicular to  $y = 2x - 3$  is
  - $-\frac{1}{2}$
  - $\frac{1}{2}$
  - $-2$
  - $2$
- The length of the segment that goes from  $(3,4)$  to  $(5,9)$  is
  - $\sqrt{24}$
  - $6$
  - $\sqrt{29}$
  - $7$
- The slope of the segment that goes from  $(-1,2)$  and  $(2,8)$  is
  - $6$
  - $\frac{1}{2}$
  - $3$
  - $2$
- The  $y$ -intercept of the graph of  $3x + 2y = 1$  is
  - $\frac{1}{2}$
  - $1$
  - $2$
  - $3$



7. The linear function for the table below is

x	y
-1	1
0	3
1	5
2	7

- a)  $y = x + 2$                       b)  $y = 2x$   
 c)  $y = x + 3$                       d)  $y = 2x + 3$

8. In the table given below, the 2<sup>nd</sup> column represents the function  $y = x^2$ . The 3<sup>rd</sup> column then would represent

x	$y = x^2$	$y = ?$
-2	4	7
-1	1	4
0	0	3
1	1	4
2	4	7

- a)  $y = x^2 + 3$                       b)  $y = (x + 3)^2$   
 c)  $y = x^2 - 3$                       d)  $y = 3x^2 + 1$

9. The equation of the y-axis is

- a)  $xy = 0$                               b)  $y = 0$   
 c)  $x + y = 0$                           d)  $x = 0$

10. The slope of  $2x + 3y = 6$  is

- a) 2    b)  $\frac{3}{2}$     c)  $-\frac{2}{3}$     d) 3

## Pre/Post Test Answer Key

1. B
2. B
3. A
4. C
5. D
6. A
7. D
8. A
9. D
10. C

# Participant Outcomes

- Demonstrate understanding of the mathematics behind linear functions.
- Demonstrate understanding of the mathematics of why a graph is considered linear.
- Demonstrate how to graph linear equations and inequalities.
- Demonstrate how to deduce standard formulas.
- Demonstrate the definition of concepts through geometric arguments.

# Standard 6

## From Algebra I Grade 8

Students graph a linear equation, and compute the  $x$  and  $y$ -intercepts (e.g.,  $2x + 6y = 4$ ). They are also able to sketch the region defined by the linear inequality (e.g., sketch the region defined by  $2x + 6y < 4$ ).

## Definition of Terms

- A point in the plane is an ordered pair of real numbers. The first number is sometimes called the x-coordinate. The second number is sometimes called the y-coordinate.
- A relation is any set of ordered pairs of real numbers. The domain of a relation is the set of all first coordinates of the relation. The range of a relation is the set of all second coordinates of the relation.
- An example of a relation is  $\{(x, y) : x^2 + y^2 = 1 \text{ and } -1 \leq x \leq 1\}$ . This is the set of all ordered pairs of real numbers  $x$  and  $y$  which satisfy the equation  $x^2 + y^2 = 1$ , the equation of the circle of radius 1 centered at the origin. The graph of this relation is this circle. The domain of this relation is the interval  $[-1, 1]$ .  $[-1, 1]$  is also the range of this particular relation. This relation is not a function.

## Definition of Terms Continued

- A function is a relation such that for any first coordinate in the domain, there is one and only one second coordinate. A function given by a formula of the form  $y = f(x)$  is a relation because it may be regarded as the collection of all ordered pairs of numbers of the form  $(x, f(x))$  where  $x$  is in the domain of the function. The  $x$ -coordinate is the independent variable. The  $y$ -coordinate is the dependent variable.
- Not every relation is a function, but every function is a relation.

Determine the domain and range of the relations listed below and determine if the relation is a function?

1.  $x = \{(-2,3), (2,1), (3,4), (4,5)\}$

2.  $y = \{(3,5), (4,6), (2,7), (3,-6)\}$

3.  $z = \{(-2, 4), (1,4), (2,4), (3,4)\}$

- Determine the domain and range of these relations.
  - Keep in mind that every function is a relation, but not every relation is a function.
  - Determine which of these relations are functions.
- 1)  $x = \{(-2,3) (2,1) (3,4) (4,5)\}$  function.  
Domain =  $\{-2,2,3,4\}$  Range =  $\{1,3,4,5\}$
  - 2)  $y = \{(3,5) (4,6) (2,7) (3,-6)\}$   
Domain =  $\{2,3,4\}$  Range =  $\{5,6,7,-6\}$   
Not a function as 3 was assigned two different values for its 2<sup>nd</sup> element 5 and  $-6$ .
  - 3)  $z = \{(-2,4) (1,4) (2,4) (3,4)\}$   
Domain =  $\{-2,1,2,3\}$  Range =  $\{4\}$   
Function: All ordered pairs have different first coordinates.



## Alternative Definition of a Function

A function from the set of real numbers to the set of real numbers is a rule which assigns to each real number  $x$  exactly one real number  $y$ . If the function evaluated at the number  $x$  is denoted by  $f(x)$  then  $y = f(x)$ .

### Examples

1.  $f(x) = x + 2$

2.  $f(x) = x^2$

3.  $f(x) = 2x^3$

## The graph of a function....

The graph of a function  $f(x)$  is the set of all ordered pairs of numbers  $(x, f(x))$ , where  $x$  can be any real number in the domain of the function. These points can be plotted in the  $xy$ -plane and the picture they form together is sometimes referred to as the graph of the function  $f(x)$ .

The Domain of a function is the set of all x-values of the function.

The Range of a function is the set of all y-values of the function.

Complete the table and graph  $y = x^2$

x	$y = x^2$
-2	
-1	
0	
1	
2	

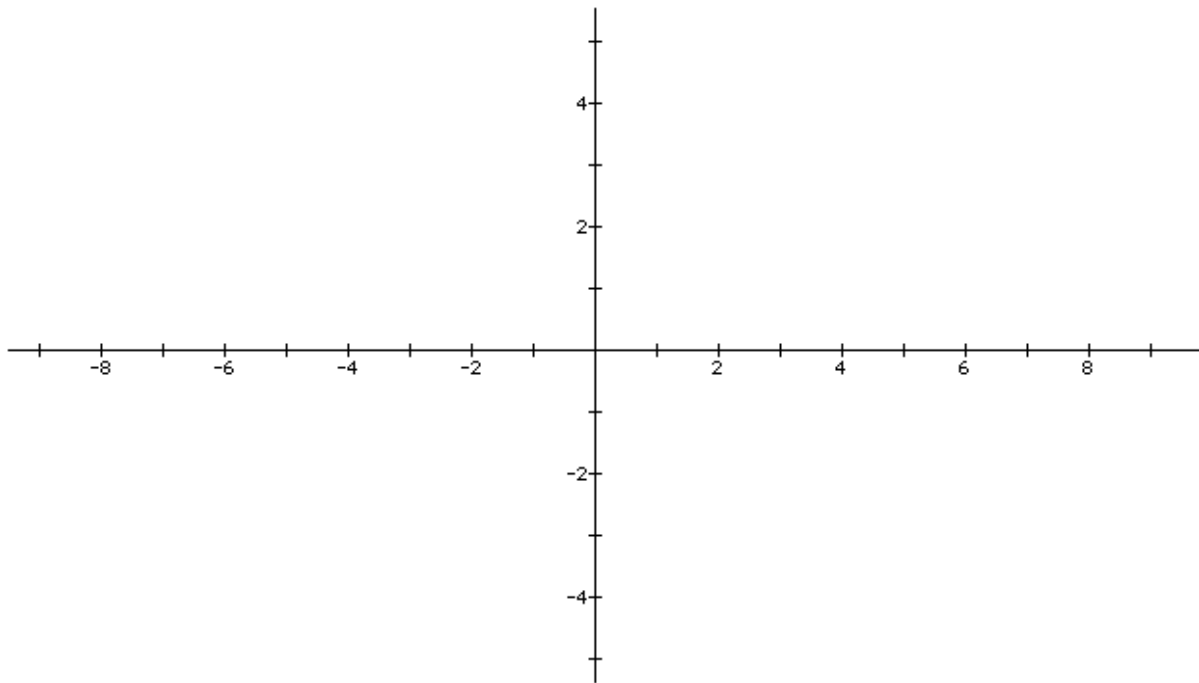

Complete the table and graph  $y = x^2$

x	$y = x^2$
-2	$(-2)^2 = 4$
-1	$(-1)^2 = 1$
0	$(0)^2 = 0$
1	$(1)^2 = 1$
2	$(2)^2 = 4$

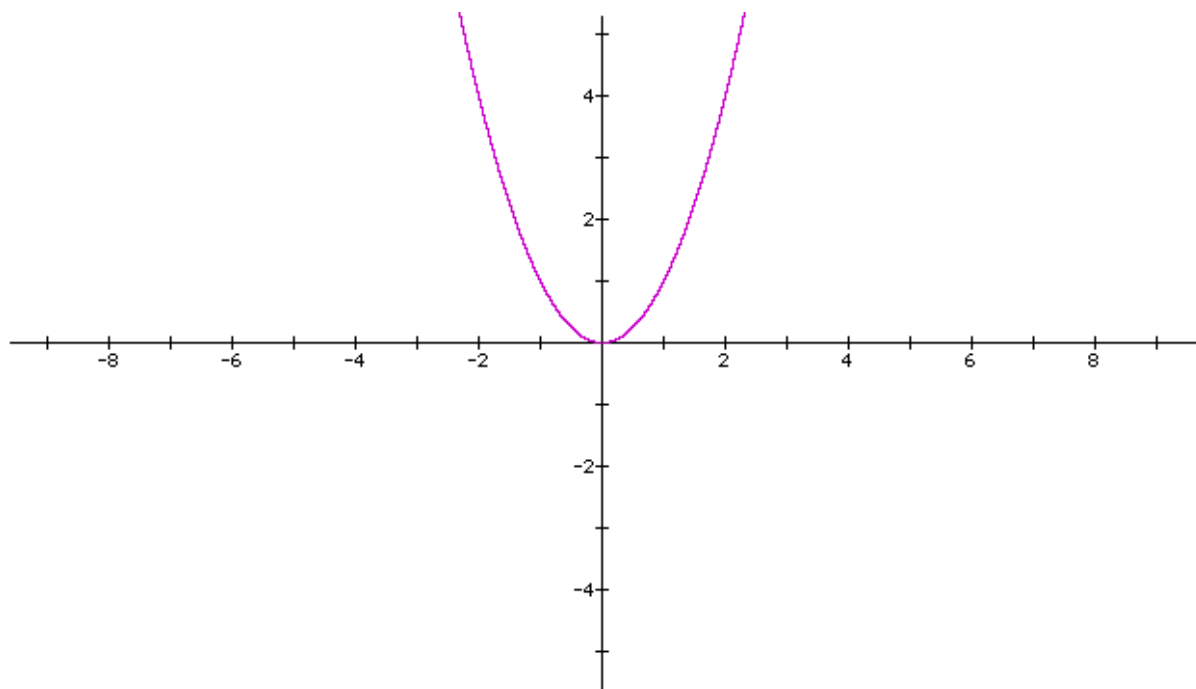

# Practice

For the points identified in the table:

What are the values in the domain?

What are the values in the range?

Extra Credit: What is the domain of the function  $y = x^2$ ?

What is the range?

## Vertical Line Test

If each vertical line in the  $x$ - $y$  plane intersects a particular graph in at most one point, then that graph is the graph of a function.

Determine whether the graphs below are the graphs of functions.

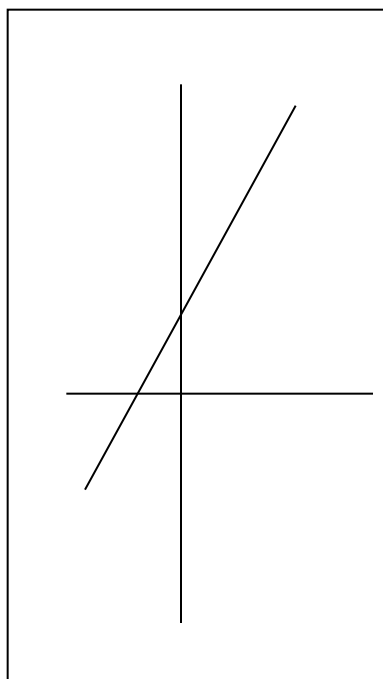
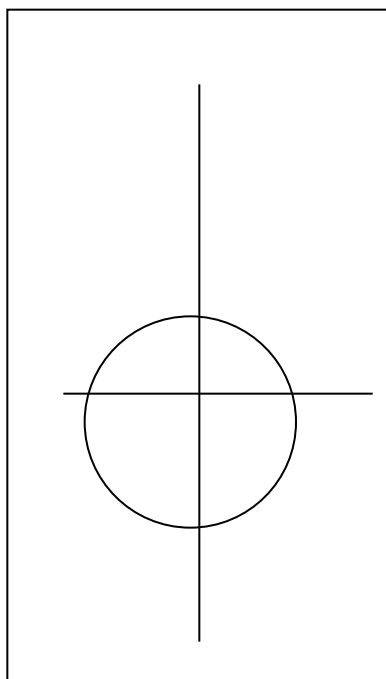
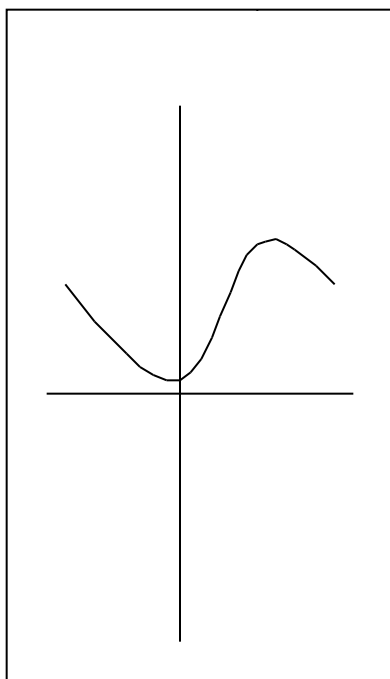

Solution:

Use the vertical line test

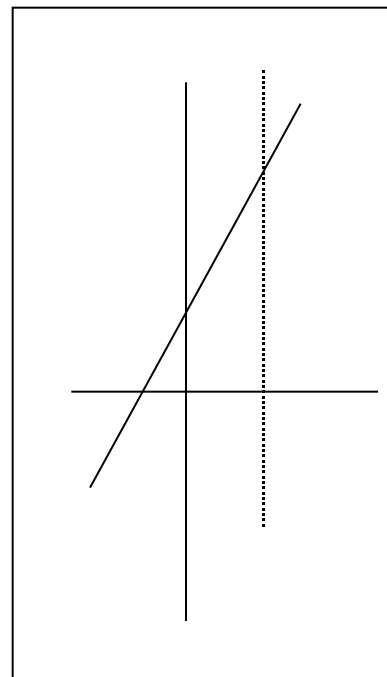
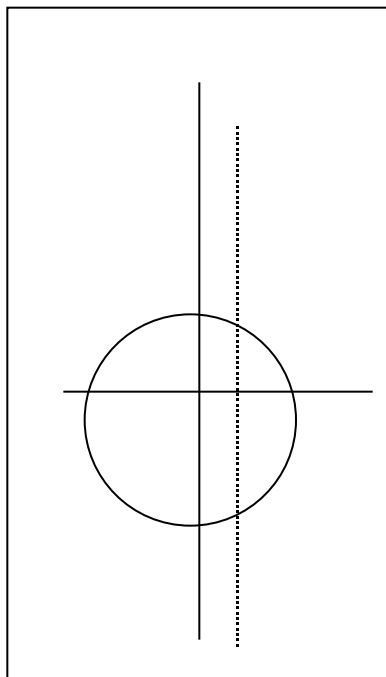
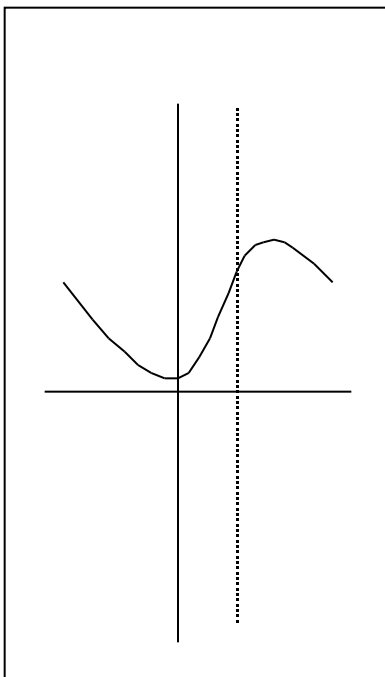

Any vertical line intersects the graph in at most one point.

This is the graph of a function

A vertical line intersects the graph in two points.

This is NOT the graph of a function

Any vertical line intersects the graph in at most one point.

This is the graph of a function



## Now Try These

Determine the domain and range of these relations and determine if the relation is a function.

1)  $A = \{(-2,3), (-1,0), (0,1), (1,3)\}$

2)  $B = \{(5,-2), (4,-3), (5,1), (3,5)\}$

3)  $C = \{(5,2), (4,2), (3,2), (2,2)\}$

4)

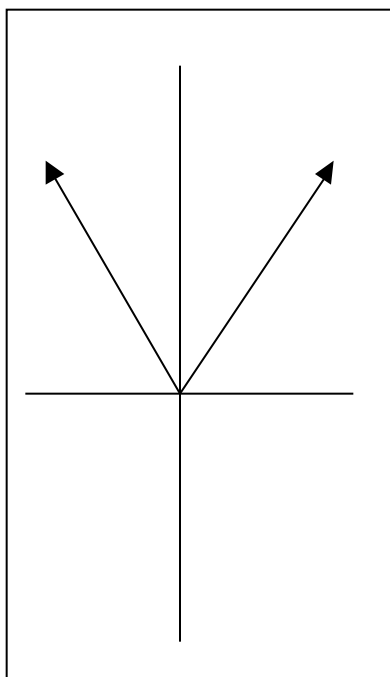

5)

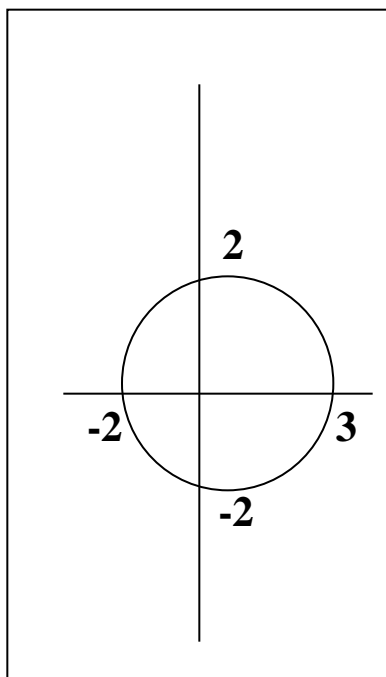

6)

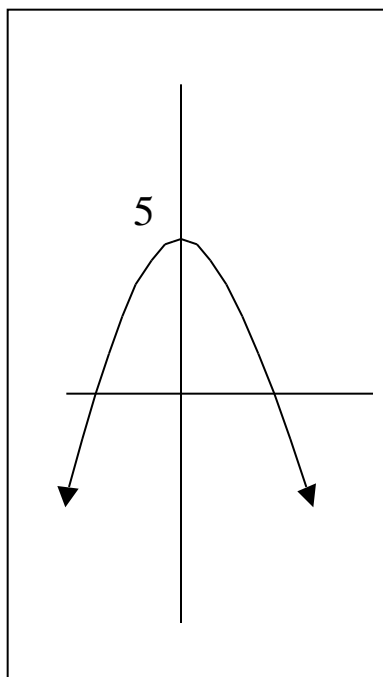

## Solution:

1) Domain  $\{-2, -1, 0, 1\}$  Range  $\{3, 0, 1\}$  Function

2) Domain  $\{5, 4, 3\}$  Range  $\{-2, -3, 1, 5\}$   
Not a function

3) Domain  $\{5, 4, 3, 2\}$  Range  $\{2\}$  Function

4)

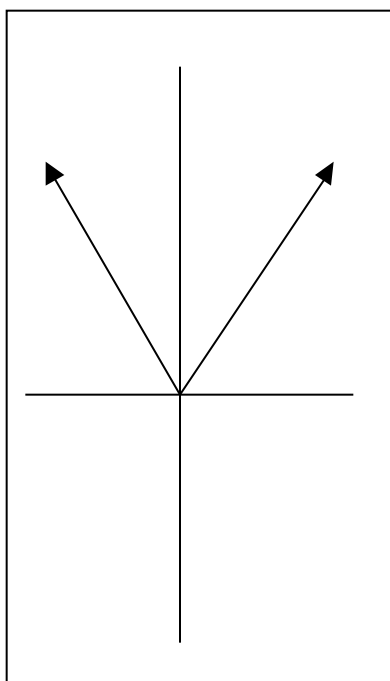

Domain: all real nos.

Range:  $\{y: y \geq 0\}$

Passes Vertical line test

Function

5)

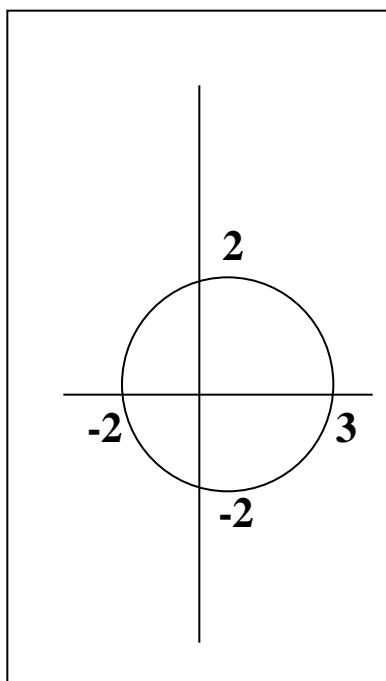

Domain:  
 $\{x: -2 \leq x \leq 3\}$

Range:  
 $\{y: -2 \leq y \leq 2\}$

Fails Vertical Line Test  
NOT Function

6)

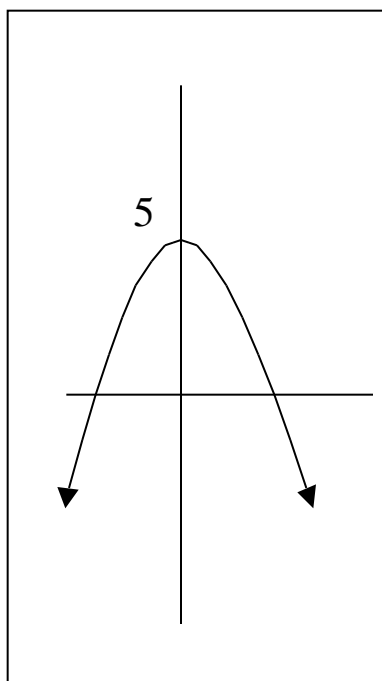

Domain: all real nos.

Range:  $\{y: y \leq 5\}$

Passes Vertical line test

Function

Let's take a look at some more examples of functions