

Exam 3, Math 310 Fall 2008, VERSION B

Name: _____

1. (6 points) Find the value of x and z if $y = 5$.

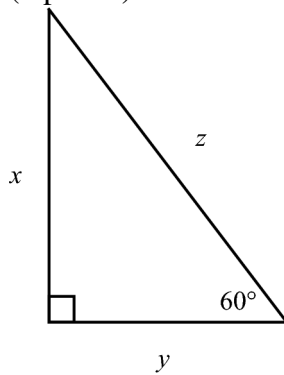

2. Answer the following questions about the figure. Lines that appear straight are straight.

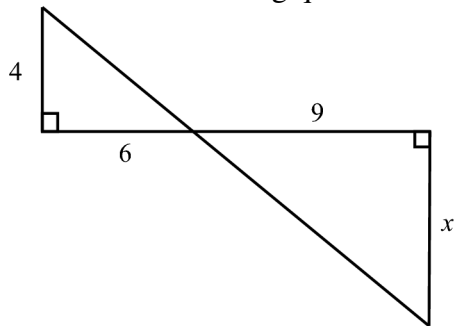

- a) (4 points) Explain why these two triangles are similar.

- b) (3 points) What is the scale factor?

- c) (4 points) Find x .

- d) (4 points) What is the ratio of areas of these triangles?

3. (5 points) The radius of a circular wheel is 2 ft. How far does it travel in 20 revolutions? (Use correct units and leave your answer in terms of π .)
4. (7 points) Use similar triangles to solve the following problem. A tree is 30 feet high and casts a shadow that is 40 feet long. A man standing nearby casts a shadow that is 8 feet long. How tall is the man?
5. You travel 8 miles due south, 2 miles due east, 3 miles due north, and then 8 more miles due east.
- a) (6 points) How far are you from your starting point?
- b) (3 points) On a map with scale 1 cm = 5 miles, the distance you found in part (a) would be shown as _____ cm.

9. A child says: "I don't get it! 1 yard = 3 feet, right? So why doesn't 2 square yards = 6 square feet?"

a) (2 points) Give the correct conversion: 2 square yards = _____ square feet.

b) (5 points) How would you help this child understand this conversion? (Feel free to draw pictures if that would be helpful.)

10. (10 points) Find the volume and surface area of the right triangular prism given below.

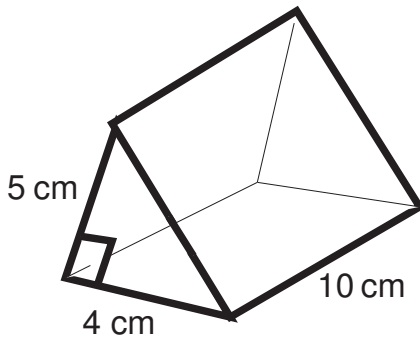

Volume = _____ Surface area = _____

11. (2 points) The following is a *net* for a polyhedron. What is the BEST name for this polyhedron?

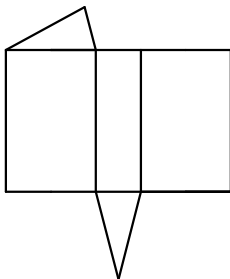

12. (2 points each) The following are polyhedra. Give the BEST name for each.

a.

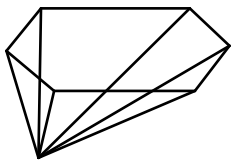

b.

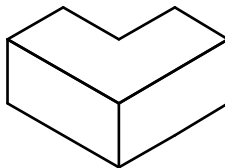

13. a. (3 points) Sketch the three-dimensional shape that has the net shown. (The middle part is a rectangle.)

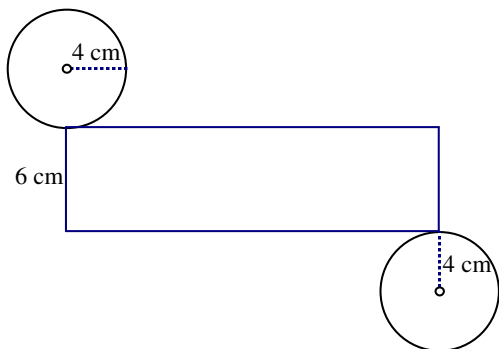

b. (2 points) Name the three-dimensional shape as fully as possible. _____

c. (8 points) Give the volume and surface area of the three-dimensional shape. (Use correct units and leave your answers in terms of π . Show your work for credit.)

Volume = _____

Surface area = _____