



36509E2

Math 310 Spring 2009, Exam 2, Version A

Name: _____

Show all work.

1. (5 pts) If two figures have the same area, must they also (always) have the same perimeter? If so, explain why. If not, give a counterexample and show that your counterexample works!

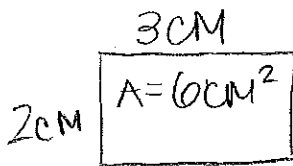

$$P = (2)2 + 2(3)$$

$$= 4 + 6$$

$$= 10 \text{ cm}$$

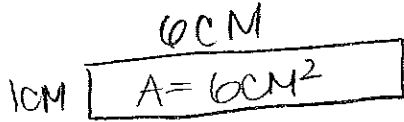

$$P = (6)2 + (1)2$$

$$= 12 + 2$$

$$= 14 \text{ cm}$$

NO

2. (4 pts) Complete the following definition. A polygon is regular if

i) all side lengths are \cong

and

ii) all int/ext angles are \cong

3. (6 pts) Given that $\overline{AC} \parallel \overline{DE}$, find x , y , and z .

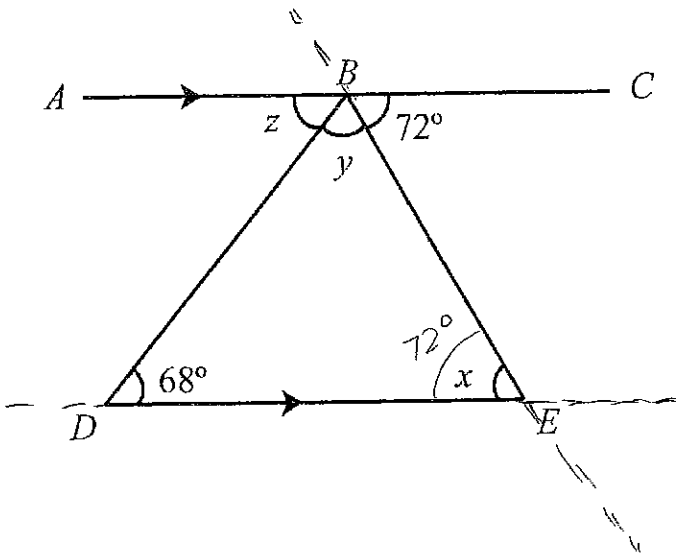

$$x = 72^\circ \text{ (alt int } \angle \text{'s } \parallel \text{-lines)}$$

$$z = 68^\circ \text{ (alt int } \angle \text{'s } \parallel \text{-lines)}$$

$$y = 180 - (72 + 68) \text{ (} \angle \text{ on st. line)}$$

$$y = 180 - 140$$

$$y = 40^\circ$$

4. (8 pts) ABCD is a rhombus. Prove that angle DAC is congruent to angle BAC.

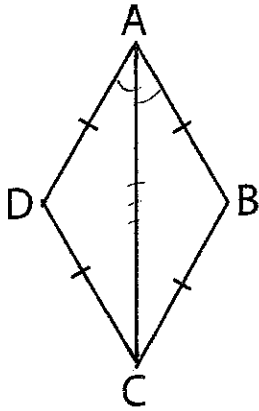

$AB = BC = CD = DA$ (given)
 $AC = AC$ (common)
 $\triangle ADC \cong \triangle ABC$ (SSS)
 $\therefore \angle DAC \cong \angle BAC$ (CPCTC)

5. (6 pts) In the picture, XYZW is a rectangle and PXQW is a rhombus. Find the value of a.

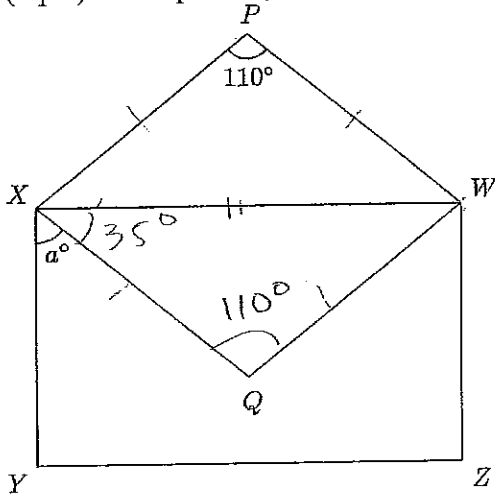

$\triangle XPW \cong \triangle WQX$ (SSS)
 $\therefore \angle XQW \cong \angle XPW$ (CPCTC)

$\triangle XQW$ is an isosceles \triangle
 b/c both sides are \cong
 base \angle 's are \cong

$$\angle QXW = \frac{180 - 110}{2} = \frac{70}{2} = 35^\circ$$

$$\angle a = 90 - 35^\circ \quad (\angle \text{'s in rect. are } 90^\circ)$$

$$\boxed{\angle a = 55^\circ}$$

6. (4 points) Find x and y in the figure below.

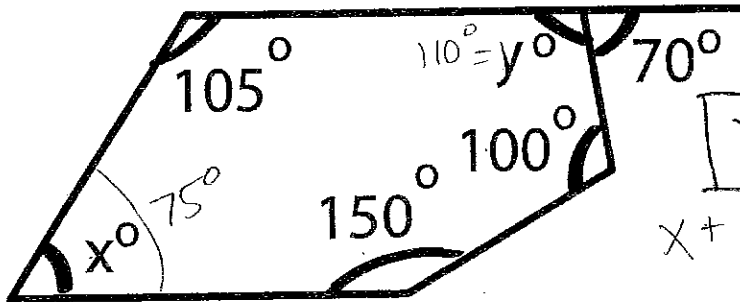

$$(5-2)180 = 540^\circ$$

$$y = 180 - 70^\circ \quad (\angle \text{'s st. line})$$

$$\boxed{y = 110^\circ}$$

$$x + 105 + 110 + 100 + 150 = 540$$

$$x + 465 = 540$$

$$\boxed{x = 75^\circ}$$

1st extend transversal and // lines

7. (8 pts) Give a Teacher's Solution: Find the value of z.

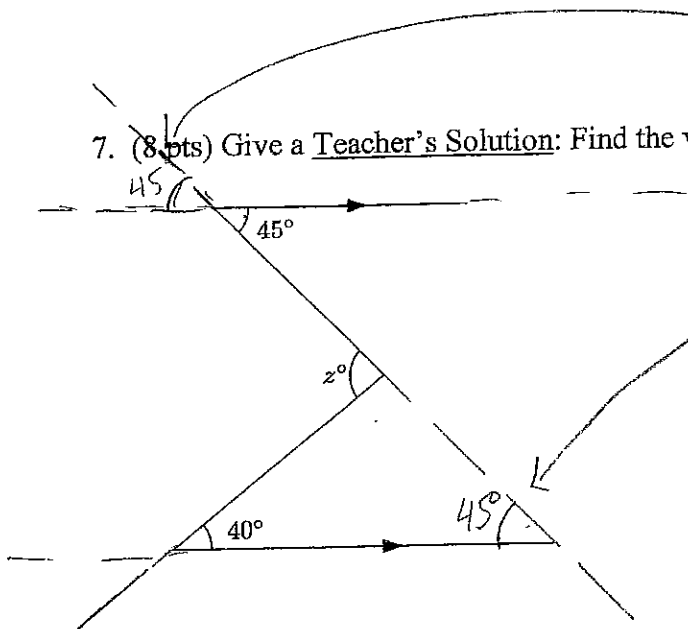

(vert \angle)

(corres. \angle // lines)

$$\therefore \angle z = 40 + 45 \text{ (ext } \angle \text{ of } \Delta)$$

$$\angle z = 85^\circ$$

Nice!!!

8. (6 pts) Each interior angle of a regular n -gon measures 162 degrees. How many sides does the n -gon have? Explain your answer.

$$\frac{(n-2)180}{n} = 162^\circ$$

$$\begin{aligned} (n-2)180 &= 162n \\ 180n - 360 &= 162n \\ -360 &= -18n \end{aligned}$$

$$\boxed{n = 20}$$

check:

$$\frac{(20-2)180}{20} = \frac{18(180)}{20} = 162^\circ$$

9. (7 pts) If $\overline{AB} \parallel \overline{CD}$, prove $a^\circ = 180^\circ - b^\circ$.

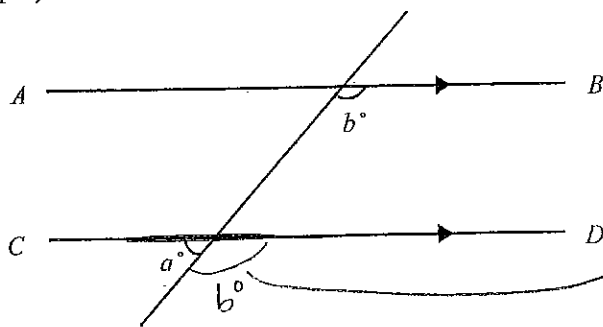

b° (corres \angle // lines)

$$a = 180^\circ - b \text{ (}\angle\text{'s on a str. line)}$$

10. (8 pts) Find the area and perimeter of the following figure, which is NOT to scale.

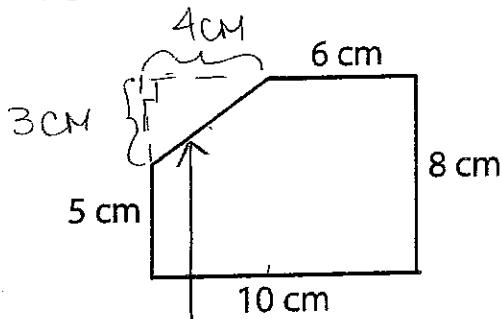

$$\begin{aligned} 3^2 + 4^2 &= c^2 \\ 9 + 16 &= c^2 \\ 25 &= c^2 \\ 5 &= c \end{aligned}$$

Area of whole figure is
 $10 \times 8 = 80 \text{ cm}^2$

$$\begin{aligned} \text{Area of } \Delta &= \frac{1}{2}(3)(4) \\ &= 6 \text{ cm}^2 \end{aligned}$$

$$\begin{aligned} \text{Area of figure} &= 80 \text{ cm}^2 - 6 \text{ cm}^2 \\ &= 74 \text{ cm}^2 \end{aligned}$$

$$\begin{aligned} \text{Perimeter} &= \\ 5 + 10 + 8 + 6 + 5 &= 34 \text{ cm} \end{aligned}$$

11. (6 pts) Find the perimeter and area of the following sector of a circle.

$$\frac{60}{360} = \frac{1}{6}$$

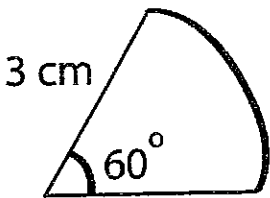

$$\begin{aligned} \text{Area} &= [\pi(3)^2] \left(\frac{1}{6}\right) \\ &= (\pi \cdot 9) \left(\frac{1}{6}\right) \\ &= \frac{9}{6} \pi \\ &= \frac{3}{2} \pi \text{ cm}^2 \end{aligned}$$

$$\begin{aligned} c &= [2\pi(3)] \left(\frac{1}{6}\right) \\ &= (6\pi) \left(\frac{1}{6}\right) \\ &= \pi \text{ cm} \end{aligned}$$

$$\begin{aligned} \text{Per} &= 3 \text{ cm} + 3 \text{ cm} + \pi \text{ cm} \\ &= (6 + \pi) \text{ cm} \end{aligned}$$

12. (5 points) Clifford walks 9 blocks due south, 2 blocks due east, 3 blocks due south, and 3 blocks due east. How many blocks is he from where he started?

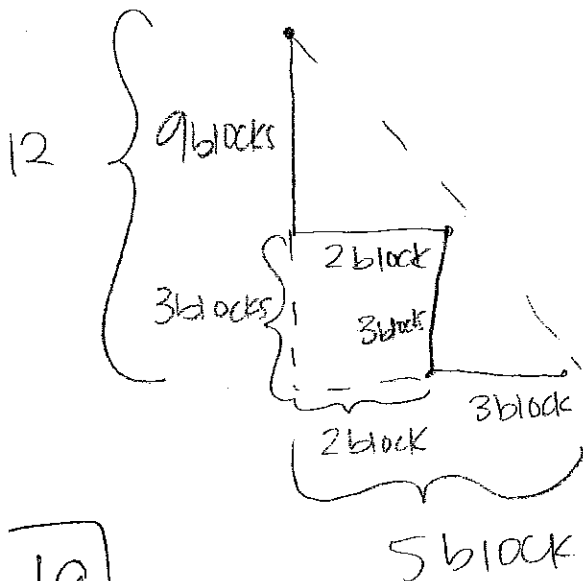

$$(12)^2 + (5)^2 = c^2$$

$$144 + 25 = c^2$$

$$169 = c^2$$

$$c = 13$$

He is 13 blocks from where he started

13. (3 pts) Determine whether the following statement is true or false: A right triangle can have legs of lengths 2 and 3 and hypotenuse of length 5. Explain your answer.

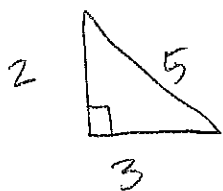

→ use Pythagorean theorem to prove:

$$(2)^2 + (3)^2 = (5)^2$$

$$4 + 9 = 25$$

$$13 \neq 25$$

False

14. (8 pts) ABCD is a parallelogram. Prove that AB=DC and AD=BC.

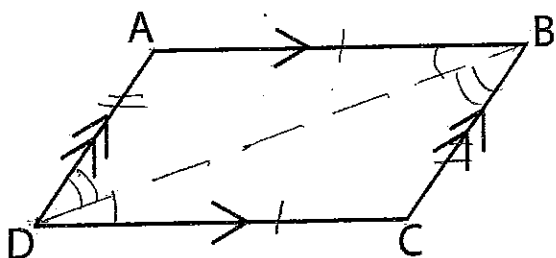

$$\angle ABD \cong \angle CDB \quad (\text{alt int } \angle // \text{ lines})$$

$$BD = BD \quad (\text{common})$$

$$\angle ADB \cong \angle CBD \quad (\text{alt int } \angle // \text{ lines})$$

$$\therefore \triangle DAB \cong \triangle BCD \quad (\text{ASA})$$

$$AB = DC$$

CPCTC

$$AD = BC$$

CPCTC

15. (6 pts) Can the parallelogram below be used to tessellate the plane? Give a detailed explanation (with pictures) to explain why it can or cannot.

* angles in the center
add to 360°

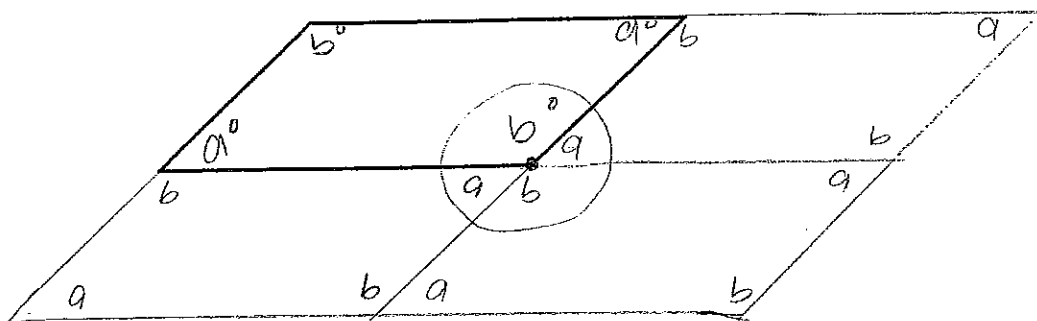

- opp \angle 's in //ogram are \cong
- int \angle 's of //ogram are supplementary

16. (5 pts) Use straightedge and compass only to precisely construct a 60 degree angle. Show all construction marks; neatness and accuracy count.

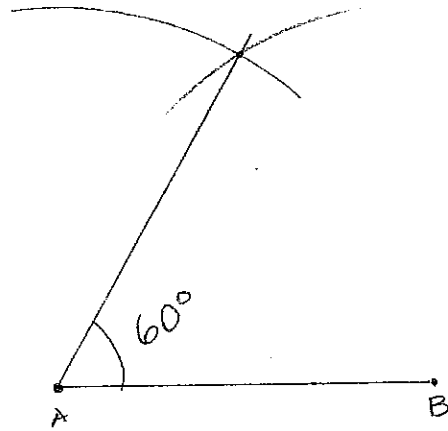

17. (5 pts) Use straightedge and compass only to precisely construct the altitude to base b, which is given in the picture below. Show all construction marks; neatness and accuracy count.

