

7

Electronic Structure of Atoms

Learning Objectives

As you work through this chapter you will learn how to:

- ▶ characterize electromagnetic radiation.
- ▶ describe the Rutherford/Bohr model of the atom.
- ▶ describe the quantum mechanical model of the atom.
- ▶ write the electron configuration of an atom.
- ▶ use the periodic table to determine the valence electron configuration of an atom.
- ▶ use electron configurations to explain chemical properties.

7.1 Introduction

In Chapter 3 you learned that elements classified as metals tend to lose electrons to form cations while nonmetallic elements tend to gain electrons to form anions. You also learned of patterns regarding the likely ion charge formed by many of the elements. For example, you learned that sodium atoms tend to form Na^+ ions while aluminum atoms tend to form Al^{3+} ions. However, at the time we didn't consider why this is the case. The question of why electrons are not drawn into the nucleus was also mentioned, but again an explanation was not provided. In Chapter 6 it was noted that the nucleus of an oxygen atom attracts the electron cloud more strongly than does hydrogen when these atoms share electrons to form a covalent bond, but no explanation was offered as to why this is the case. All of these unanswered questions plus additional interesting ideas, such as how the size of atoms varies among the elements, are explained by the current theory of the electronic structure of the atom. This is because each element has a unique atomic number and hence a unique number of protons and electrons. Scientists have learned that

the varying properties of the elements are fundamentally linked to the number of protons and electrons present.

A description of the electronic structure of atoms started to take shape with the discovery of the electron as a particle smaller than an atom in 1897 by the British physicist J. J. Thomson. During the next 50 years the details of the electronic structure of the atom were developed by scores of scientists including 16 Nobel Prize winners. The current theory is both mathematical and at times counter-intuitive, and many facets of this theory have no easily observable analogy in everyday life. Consequently, many of the details are beyond the scope of this preparatory class. However, some basic ideas that are at the core of this theory are appropriate topics for this course and worth investigating in order for you to establish the proper mindset for your subsequent chemistry courses. The first step toward an appreciation of the electronic structure of atoms begins with a discussion about light.

7.2 Electromagnetic Radiation

For most individuals the world is keenly perceived by the sense of sight. Objects are detected by visible light that is absorbed within the structure of the eye. However, not all **electromagnetic radiation** is perceived by our eyes. In fact, visible light constitutes a rather small portion of the **electromagnetic spectrum** (Fig. 7.1).

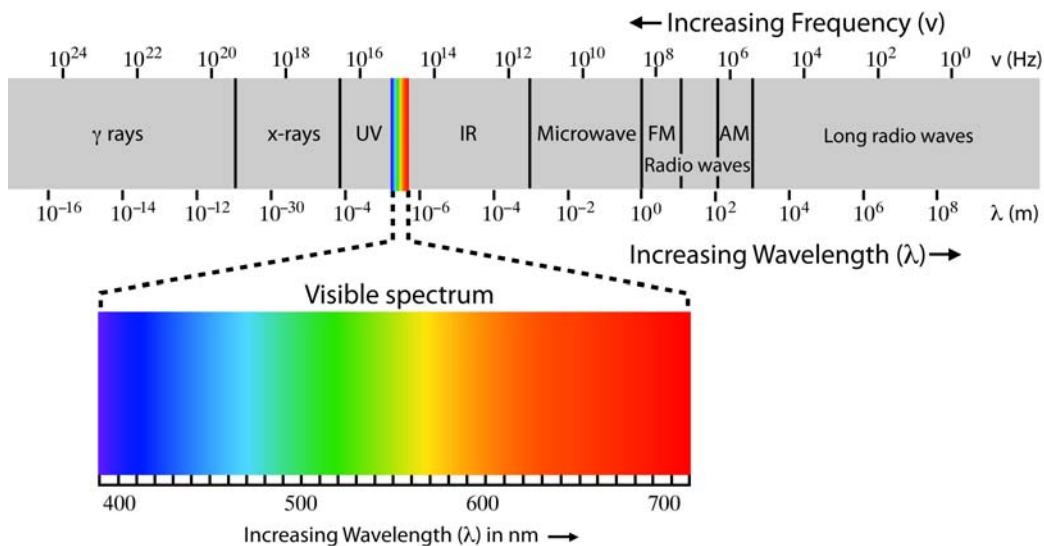

Figure 7.1 Electromagnetic spectrum

The electromagnetic spectrum consists of all the various forms of radiation including familiar ones such as **microwave radiation**, **infrared (IR) radiation**, **visible light**, **ultraviolet (UV) radiation** and **x-rays**. This spectrum, like the rainbow of colors associated with visible light, is continuous (there are no gaps) as one form of radiation blends into another.

Electromagnetic radiation can be described as a wave similar to the ripple produced when a stone is thrown into a pond. Modern physics suggests that this wave is composed of perpendicular oscillating electric and magnetic fields (Fig. 7.2). An important characteristic of an electromagnetic wave is its **wavelength** (symbolized by the Greek letter lambda, λ), the distance in space between any two analogous points on adjacent waves (Fig. 7.3). A distance of one wavelength corresponds to one **cycle** of the wave, so the SI unit for wavelength is m/cycle although the denominator is usually understood and omitted. **Radio waves**, used for television, radio and mobile phone data transmission, have the longest wavelengths ranging from about a meter to thousands of meters (several miles). **Gamma radiation** (γ rays) has the shortest wavelengths, less than 10 pm and smaller than the size of individual atoms. The human eye is sensitive to the portion of the electromagnetic spectrum corresponding to wavelengths from about 400-750 nm. This range is referred to as visible light. The colors of the visible light rainbow are associated with wavelengths from red (~ 750 nm) to violet (~ 400 nm).

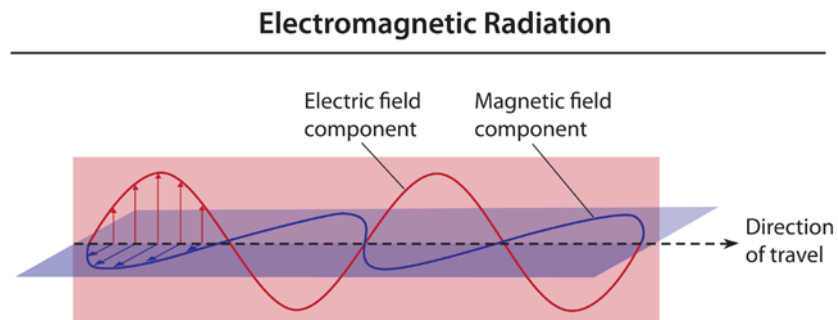

Figure 7.2 Wave description of electromagnetic radiation

The **amplitude** of an electromagnetic wave (Fig. 7.3) is associated with the intensity of the radiation. The brighter a light source is, the larger the amplitude of the associated waves.

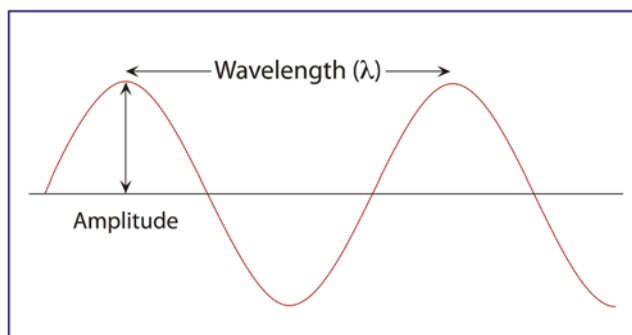

Figure 7.3 Wavelength and amplitude of a wave

Another fundamental property of wave phenomena is **frequency** (symbolized by the Greek letter nu, ν). The frequency of a wave is the number of wavelengths (or cycles) that pass an observation point per unit time. Assuming the waves are traveling at the same speed, a high frequency wave will have a shorter wavelength than a low frequency wave. The SI unit for frequency is the **hertz** (Hz); 1 Hz = 1 cycle/s. Figure 7.4 illustrates the difference between a high frequency (short wavelength) and a low frequency (long wavelength) wave.

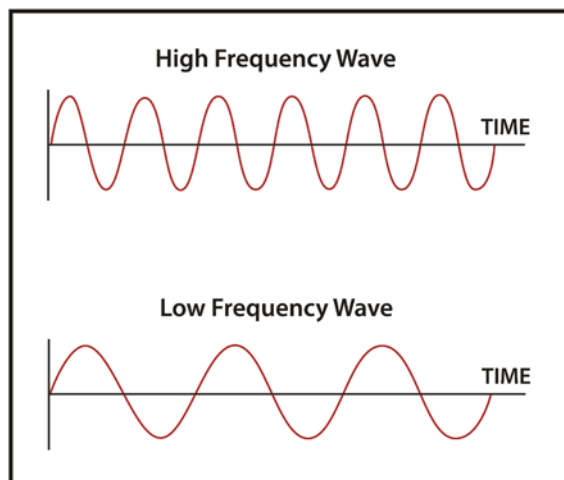

Figure 7.4 A comparison of high and low frequency waves

Since a high frequency is associated with a short wavelength we can say that frequency and wavelength are inversely proportional to each other. Mathematically we can express this relationship as:

$$\nu \propto \frac{1}{\lambda}$$

The proportionality constant needed to make this relationship an equality can be surmised by looking at the product of frequency and wavelength in terms of the units involved.

$$\nu \times \lambda = \frac{\text{cycles}}{\text{s}} \times \frac{\text{m}}{\text{cycle}} = \frac{\text{m}}{\text{s}}$$

The product has units of speed (distance/time) and, in fact, the proportionality constant is the speed of the wave. In a vacuum all forms of electromagnetic radiation have the same speed, usually referred to as the **speed of light** and designated c , which is equal to exactly 299,792,458 m/s. Therefore,

$$\nu = \frac{c}{\lambda} \quad (7.1)$$

According to theories in modern physics, the speed of light is the upper limit in speed that any object of mass can attain.

As electromagnetic radiation passes through something other than a vacuum it appears to be slowed down as it interacts with electrons in the substance. A low density substance such as air has a minimal effect on the progress of the electromagnetic wave. For calculations in this class use 3.00×10^8 m/s for the speed of electromagnetic radiation.

Check for Understanding 7.1

Solutions

1. What is the wavelength in meters of a radio wave having a frequency of 88.5 MHz?
2. What is the frequency of green light having a wavelength of 510 nm?

By the end of the nineteenth century most physicists believed that the various properties of electromagnetic radiation could be explained by treating it as a wave. However, the classical wave theory of light did not provide a satisfactory explanation for the **photoelectric effect** which was discovered in 1887 by Heinrich Hertz. The photoelectric effect refers to the emission of electrons from the surface of a material when it is illuminated with electromagnetic radiation (Fig. 7.5).

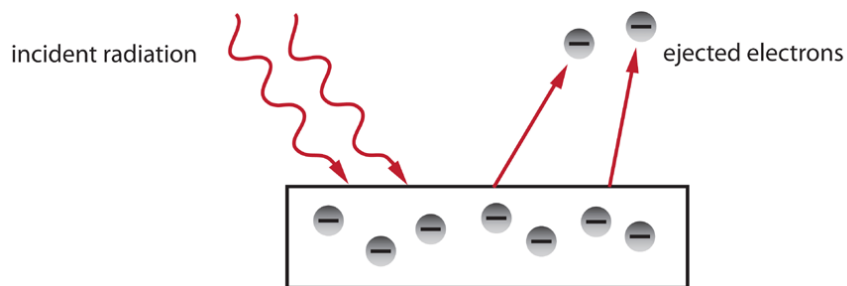

Figure 7.5 Photoelectric effect: The emission of electrons from the surface of a material when it absorbs electromagnetic radiation

Experiments showed that for a particular metal: (1) electrons would not be emitted if the frequency of the incident radiation was below a certain value; (2) the energy of the ejected electrons increased with increasing frequency of the incident light; and (3) the number of electrons emitted was proportional to the intensity (brightness) of the incident light, but the maximum kinetic energy of the electrons did not change with light intensity. These results were not consistent with the wave theory of light. In 1905 Albert Einstein, using ideas first formulated by Max Planck (1858-1947), was able to explain the photoelectric effect by proposing that electromagnetic radiation was composed of particles. According to Einstein, light consists of a stream of particles, later called **photons**, that have an energy (E_{photon}) related to the frequency of the light by

$$E_{\text{photon}} = h\nu \quad (7.2)$$

where h is a constant, known as **Planck's constant**, with a value of 6.626×10^{-34} J·s. When an incident photon is absorbed, its energy gets transferred to an electron. If the photon energy is high enough the electron will gain enough energy to overcome the forces of attraction within the material and it gets ejected. If the frequency of incident

light is too low, the electron will not be able to escape the material. Increasing the brightness of the incident radiation means more photons will be absorbed and more electrons ejected provided the radiation frequency is sufficiently large. The direct proportionality between the emitted electron energy and the frequency of light was later verified and Albert Einstein won the 1921 Nobel Prize in Physics for his explanation of the photoelectric effect. In solving this problem, Einstein's work led physicists to an even bigger dilemma - how to explain that electromagnetic radiation can be described in terms of both a wave and a stream of particles. This is called the **wave-particle duality** of light.

7.3 The Bohr Atom

What do these descriptions of electromagnetic radiation have to do with the electronic structure of atoms? You may have observed how a prism disperses the “white light” from the sun into the familiar rainbow of colors (Fig. 7.6). In the 1800s numerous scientists observed that when a metal was vaporized in an electric spark it emitted a

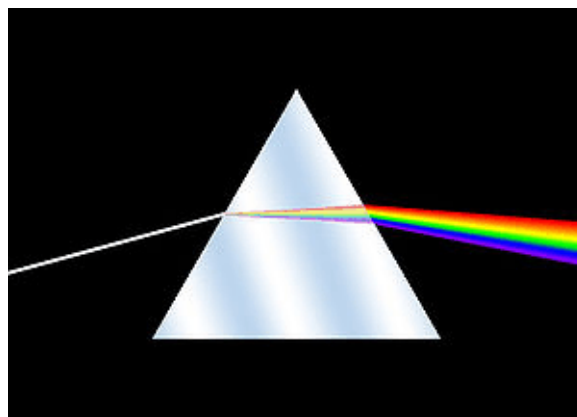

Figure 7.6 White light dispersed into a rainbow of colors by a prism

characteristic light that when viewed through a prism consisted of discrete bands of color (Fig. 7.7). It was soon realized that hot gases of each element had a unique **atomic emission spectrum** (also called a **line spectrum**) which could be used to deduce the

presence of an element in a heated sample. These emissions are responsible for the color of neon lights or the various colors associated with fireworks. The Swedish physicist Johannes Rydberg (1854-1919) was able to develop a quantitative relationship to describe the specific wavelengths emitted by certain elements, however, before the start of the twentieth century there was no satisfactory theory to account for these emissions.

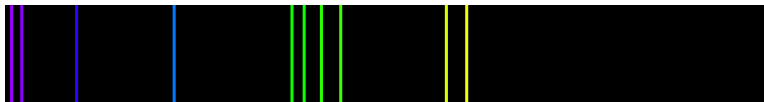

Figure 7.7 Emission spectrum of vaporized copper atoms

atomic emission spectra

As a result of experiments directed by Ernest Rutherford in 1909, the nuclear model of the atom emerged. According to this thinking, atoms consist of a dense core (later called the atomic nucleus) of positive charge surrounded by negatively-charged electrons. This planetary model of the atom with tiny electrons orbiting a very small nucleus meant that atoms were largely empty space. However, Rutherford's model suggested atoms would be unstable. Based on classical physics, the orbiting electron would be drawn eventually to the positively-charged nucleus, thereby collapsing the atom. Furthermore, this planetary model did not correctly predict the emission spectrum of different atoms. Many of these difficulties were resolved by the Danish physicist Niels Bohr (1885-1962) with his theory of atomic structure. According to the Bohr model:

- ▶ electrons can only revolve around the nucleus in specific circular orbits;
- ▶ each orbit is associated with a specific distance from the nucleus and a specific electron energy;
- ▶ electrons can only gain and lose energy by moving from one specific orbit to another.

The revolutionary idea in Bohr's model is that electrons in atoms can have only discrete energies; the electron energy is said to be **quantized** instead of continuous. This

is analogous to the difference between stairs and a ramp. When going up a set of stairs you can occupy only specific positions (heights) on the staircase, whereas when walking up a ramp you can occupy any position along the way. Your position on the stairs is quantized while your position on the ramp is continuous.

In Bohr's model, the further the electron is from the nucleus, the higher is its energy. Each Bohr orbit is characterized by an integer symbolized by n and called the **principal quantum number** ($n = 1, 2, 3, \dots$). As the value of n increases, the electron energy (E_n) also increases. Bohr also proposed that as an electron moves from a higher energy orbit (e.g., $n = 3$) to a lower energy orbit, the decrease in electron energy is emitted as electromagnetic radiation with a frequency ν . For example, if an electron moves from the $n = 3$ orbit to the $n = 2$ orbit (Fig. 7.8) the energy loss is determined by the energy difference of the levels according to:

$$\Delta E = E_3 - E_2 = h\nu$$

This allowed him to make predictions about the frequency and wavelength of atomic emission lines. While he was able to correctly predict values for the hydrogen atom emissions, he was not able to do so for other atoms. This suggested that his ideas had some measure of validity but needed revision.

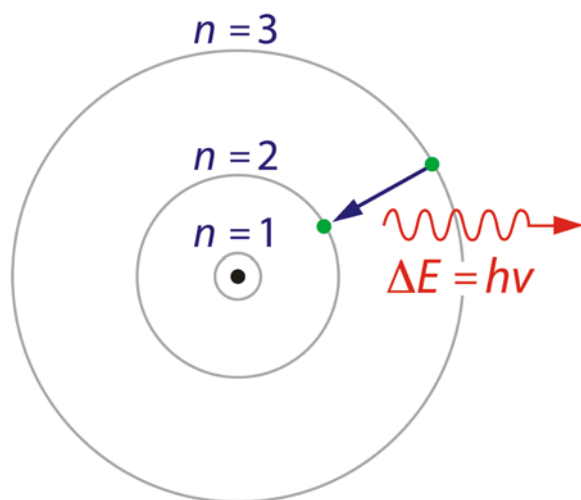

Figure 7.8 Electron moving from a higher energy orbit ($n = 3$) to a lower energy orbit ($n = 2$) in the Bohr atom model resulting in the emission of radiation

7.4 *The Quantum Mechanical Model of the Atom*

Bohr's attempt to describe the electronic structure of the atom by blending classical physics with the revolutionary idea of quantized electron energy levels was promising, but it had numerous shortcomings. Foremost, he had little justification that electrons assumed discrete stable orbits. One of the first steps toward the resolution of such issues was provided by the French physicist Louis de Broglie. In 1924 he made the astounding suggestion that all matter, not just light, has a wave-like nature. This suggested that electrons also have a wave-particle duality. A few years later his hypothesis was confirmed experimentally when electrons were observed to display fundamental wave properties.¹ In 1926 the Austrian physicist Erwin Schrödinger developed a mathematical description of electrons in atoms based on the wave properties of the electron. His ideas formed the basis for the current theory of the electronic structure of the atom and an entire area of physics known as **quantum mechanics**. The mathematics of quantum mechanics is difficult and abstract. However, the qualitative features of the modern theory of electronic structure listed below are useful and can be applied in this class.

Qualitative Features of the Quantum Mechanical Model of Electronic Structure

1. Electrons occupy definite energy states (E_n) characterized by a principal quantum number n ($n = 1, 2, 3, \dots$).

Generally $E_1 < E_2 < E_3 \dots$

The lower the electron energy the more tightly bound the electron is to the nucleus, and the closer (on the average) the electron is to the nucleus.

Electrons normally occupy the lowest energy level available. When an atom acquires energy, an electron is temporarily excited to a higher energy level and is further from the nucleus.

¹Presently, particles as large as molecules containing more than 100 atoms have been shown to exhibit wave properties.

2. Electron motion for a particular energy is unknown. Theory can only describe where the electron is likely to be found.
3. For each principal energy level n there are n **sublevels** of energy designated s, p, d, f, g, \dots

For a given value of n , sublevel energy varies $s < p < d < f \dots$

4. The energy sublevels are associated with **orbitals**, which represent regions of space around the nucleus in which the probability of finding an electron with a particular energy is greatest.

Orbital shape and orientation vary with the sublevel.

5. No more than 2 electrons can occupy the same atomic orbital. Two electrons occupying the same orbital must have opposite spins.

Notice that the current quantum mechanical model has the same feature of quantized electron energy levels as in the Bohr model, however, the Bohr orbits are replaced by *orbitals* and the motion of the electron is not defined. This model also suggested that electrons have a property called *spin*. This can be thought of as analogous to the rotation of the earth on its axis. Therefore, an electron can have only two directions of spin, clockwise and counterclockwise. Electrons spinning in the same direction are said to have **parallel spins**. Electrons in the same orbital must have opposite spins.

By considering the wave properties of an electron, the model also predicts that an electron having a particular energy will not be drawn into the nucleus, but will have a maximum probability of being found at a specific distance from the nucleus.

The quantum mechanical model identifies a series of discrete energy states for electrons in atoms. Each state is characterized by a principal quantum number and sublevel designation. Table 7.1 lists the possible energy states available to electrons up to $n = 4$.

Table 7.1 Possible energy states up to $n = 4$ for electrons in an atom

Principal energy level	Possible sublevels	Number of orbitals	Number of electrons in sublevel	Electron energy level designation
$n = 1$	s	1	2	$1s$
$n = 2$	s p	1 3	2 6	$2s$ $2p$
$n = 3$	s p d	1 3 5	2 6 10	$3s$ $3p$ $3d$
$n = 4$	s p d f	1 3 5 7	2 6 10 14	$4s$ $4p$ $4d$ $4f$

An orbital does not have a definite boundary, but chemists usually represent an orbital with a diagram indicating where the electron can be found 90% of the time. Such representations of s and p orbitals are shown in Figure 7.9.

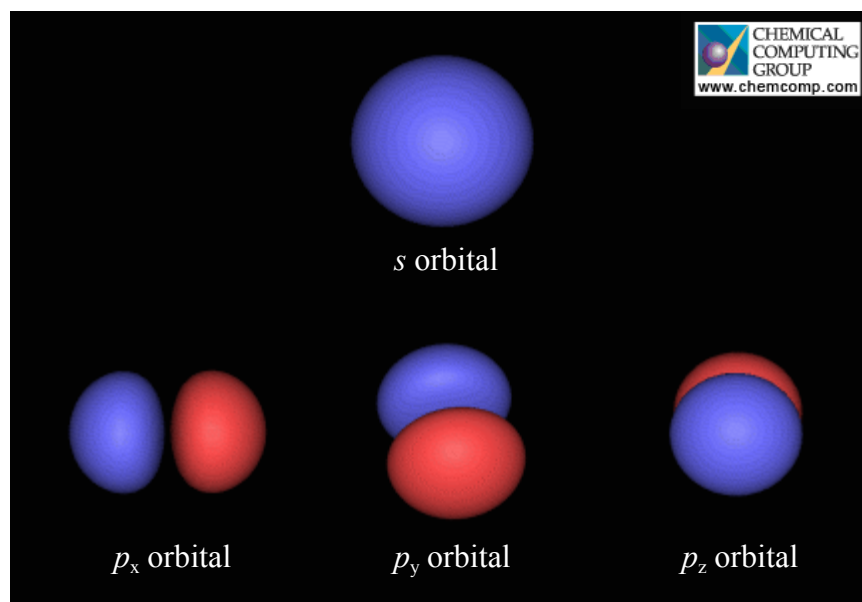

Reproduced with permission from Chemical Computing Group.

Figure 7.9 Representations of the general shapes of s and p atomic orbitals. The three p orbitals are directed along the x , y and z axes. The nucleus is in the center of the spherical s orbital and between the two lobes of each p orbital.

The electrons in an atom normally occupy the lowest energy states available. Such an arrangement is referred to as the **ground state** electron configuration. If the atom absorbs energy, an electron can be promoted to a higher energy level and the atom is said to be in an **excited state**. When an atom is in an excited state, the electron that was promoted to a higher energy level generally quickly moves to a vacancy in a lower level. When this occurs it causes the atom to emit electromagnetic radiation. For this class, electrons will be assumed to be in the ground state of an atom.

It is useful to consider the electron energy states on a relative energy diagram (Fig. 7.10). Contrary to expectations, sometimes a sublevel with a higher value of n is lower in energy than a sublevel with a smaller value of n . Notice, for example, that the $4s$ sublevel energy is slightly below that of the $3d$ sublevel energy. You will be able to anticipate such unexpected results by making use of the arrangement of the elements in the periodic table. Also note that the spacing between energy levels is not uniform; it gets smaller as the energy of the levels increases.

7.5 Electron Configurations

This model of the electronic structure of atoms allows you to describe the ground state energy levels occupied by a given number of electrons. A shorthand notation known as the **electron configuration** of an atom shows each type of orbital that is occupied and the number of electrons in it. It is written in the following format:

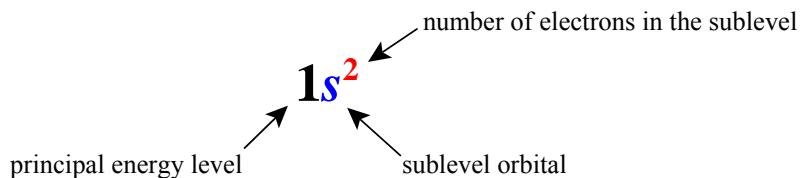

From Table 7.1 we see that for a p sublevel there are three orbitals, so it takes six electrons to fill all of these orbitals. Likewise, it takes ten electrons to fill the five orbitals in a d sublevel. Example 7.1 illustrates how to write the electron configuration for an atom.

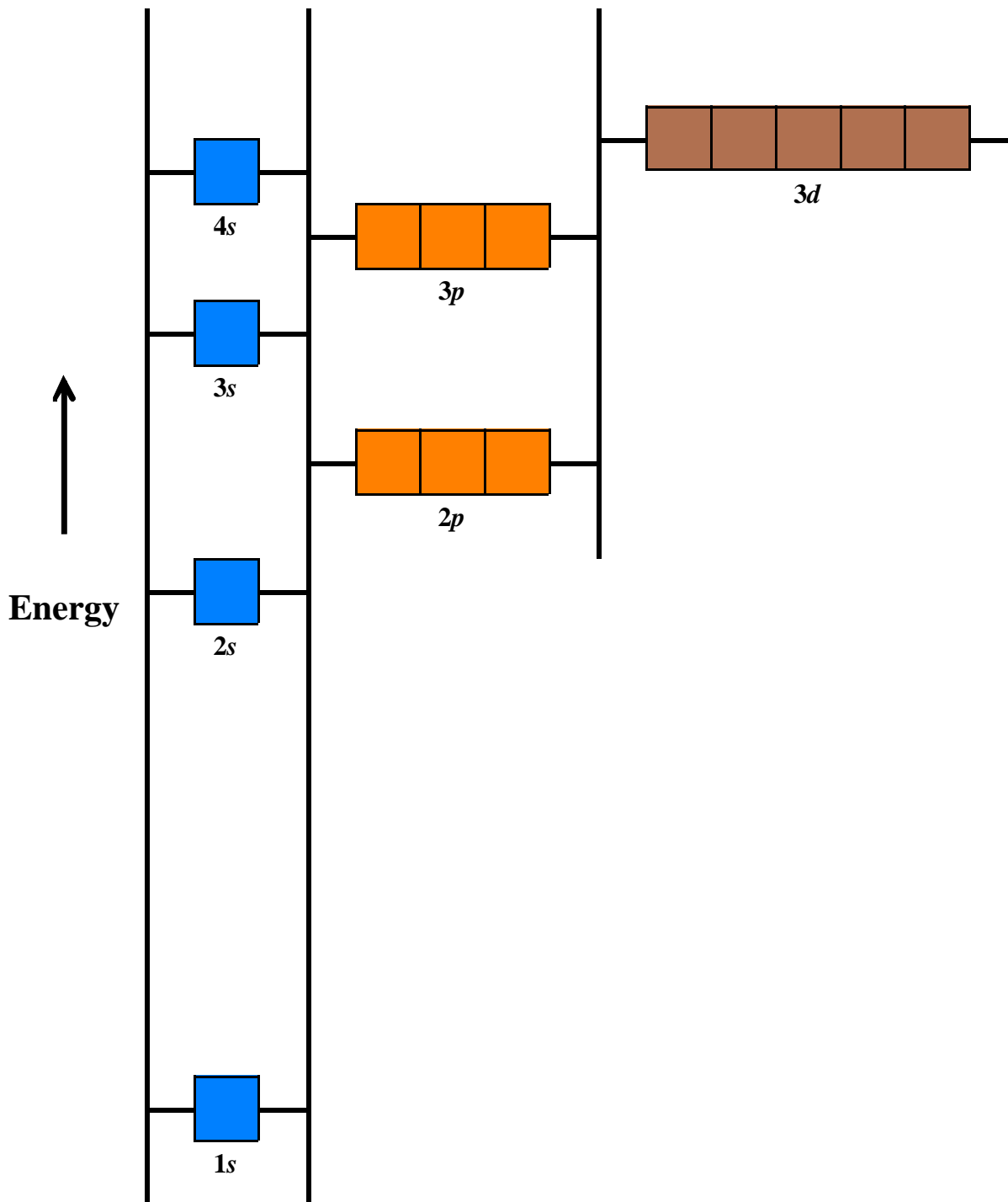

Figure 7.10 Relative electron energy levels in an atom. Each box represents an orbital which can accommodate two electrons.

Example 7.1*Problem*

What is the ground state electron configuration of a sulfur atom ?

Solution

What we know: number of electrons for a sulfur atom; the ordering of electron energy levels

Desired answer: electron configuration for sulfur

From the periodic table you can find the atomic number for sulfur ($Z=16$). This represents the number of electrons that must be accounted for in the electron configuration. From the energy level diagram in Figure 7.10, the electron energy levels go in the order $1s, 2s, 2p, 3s, 3p, 4s, 3d...$ Start filling the orbitals until all 16 electrons are accounted for; remember each orbital can have a maximum of two electrons. The correct electron configuration is shown below. Take note that the sum of the superscripts must equal the number of electrons present.

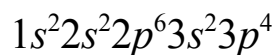
**Check for Understanding 7.2****Solutions**

1. What is the ground state electron configuration for an atom of each of the following.
a) C b) Fe

7.6 Electron Configurations and the Periodic Table

The electron configurations for the first 36 chemical elements are shown in Table 7.2. Before carefully reviewing these, we need to define the term **valence electrons**. The valence electrons of an atom are those in the principal energy level having the largest value of n . For example, carbon has 4 valence electrons ($2s^2 2p^2$) because $n = 2$ is the highest occupied principal energy level. Since valence electrons are in the highest

Table 7.2 Ground state electron configuration for elements with $Z=1$ to $Z=36$

Z	Element	Electron Configuration	Z	Element	Electron Configuration
1	H	$1s^1$	19	K	$1s^2 2s^2 2p^6 3s^2 3p^6 4s^1$
2	He	$1s^2$	20	Ca	$1s^2 2s^2 2p^6 3s^2 3p^6 4s^2$
3	Li	$1s^2 2s^1$	21	Sc	$1s^2 2s^2 2p^6 3s^2 3p^6 4s^2 3d^1$
4	Be	$1s^2 2s^2$	22	Ti	$1s^2 2s^2 2p^6 3s^2 3p^6 4s^2 3d^2$
5	B	$1s^2 2s^2 2p^1$	23	V	$1s^2 2s^2 2p^6 3s^2 3p^6 4s^2 3d^3$
6	C	$1s^2 2s^2 2p^2$	24	Cr	$1s^2 2s^2 2p^6 3s^2 3p^6 4s^1 3d^5$
7	N	$1s^2 2s^2 2p^3$	25	Mn	$1s^2 2s^2 2p^6 3s^2 3p^6 4s^2 3d^5$
8	O	$1s^2 2s^2 2p^4$	26	Fe	$1s^2 2s^2 2p^6 3s^2 3p^6 4s^2 3d^6$
9	F	$1s^2 2s^2 2p^5$	27	Co	$1s^2 2s^2 2p^6 3s^2 3p^6 4s^2 3d^7$
10	Ne	$1s^2 2s^2 2p^6$	28	Ni	$1s^2 2s^2 2p^6 3s^2 3p^6 4s^2 3d^8$
11	Na	$1s^2 2s^2 2p^6 3s^1$	29	Cu	$1s^2 2s^2 2p^6 3s^2 3p^6 4s^1 3d^{10}$
12	Mg	$1s^2 2s^2 2p^6 3s^2$	30	Zn	$1s^2 2s^2 2p^6 3s^2 3p^6 4s^2 3d^{10}$
13	Al	$1s^2 2s^2 2p^6 3s^2 3p^1$	31	Ga	$1s^2 2s^2 2p^6 3s^2 3p^6 4s^2 3d^{10} 4p^1$
14	Si	$1s^2 2s^2 2p^6 3s^2 3p^2$	32	Ge	$1s^2 2s^2 2p^6 3s^2 3p^6 4s^2 3d^{10} 4p^2$
15	P	$1s^2 2s^2 2p^6 3s^2 3p^3$	33	As	$1s^2 2s^2 2p^6 3s^2 3p^6 4s^2 3d^{10} 4p^3$
16	S	$1s^2 2s^2 2p^6 3s^2 3p^4$	34	Se	$1s^2 2s^2 2p^6 3s^2 3p^6 4s^2 3d^{10} 4p^4$
17	Cl	$1s^2 2s^2 2p^6 3s^2 3p^5$	35	Br	$1s^2 2s^2 2p^6 3s^2 3p^6 4s^2 3d^{10} 4p^5$
18	Ar	$1s^2 2s^2 2p^6 3s^2 3p^6$	36	Kr	$1s^2 2s^2 2p^6 3s^2 3p^6 4s^2 3d^{10} 4p^6$

occupied principal energy level, they are the electrons that are, on the average, farthest from the nucleus and least strongly attracted to the nucleus. They are of special importance because they are the electrons most likely to be involved in the chemical reactions of an atom. The electrons occupying the filled lower energy levels of an atom are known as the **core electrons**.

Check for Understanding 7.3

Solutions

1. How many valence electrons does an atom of each of the following elements have?
 - a) Cl
 - b) Ni

A number of important patterns emerge when one looks closely at the electron configurations of atoms (Table 7.2) and the organization of the elements in the periodic table. This should come as no great surprise since the elements in the periodic table are arranged on the basis of atomic number and, hence, number of electrons. First, notice that as you move left to right across period 2 and period 3, electrons are being added to an *s* orbital and when that is filled electrons are added to *p* orbitals. This trend continues in periods 4 and 5 except electrons are added to the *d* orbitals as you move across the transition elements. Finally, in periods 6 and 7, *f* orbitals are being filled as you move left to right across the **lanthanides** and **actinides**. These trends are summarized on the periodic table shown in Figure 7.11. Remembering this pattern will help you to anticipate the filling order of the electron energy levels and enable you to write the electron configuration of an atom. For example, locate cadmium (Cd) among the period 5 transition elements. A cadmium atom has 48 electrons. Start with hydrogen and work across from left to right and down the table until you get to cadmium. In the process you will put electrons into the following sequence of orbitals.

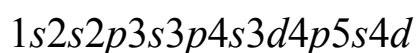

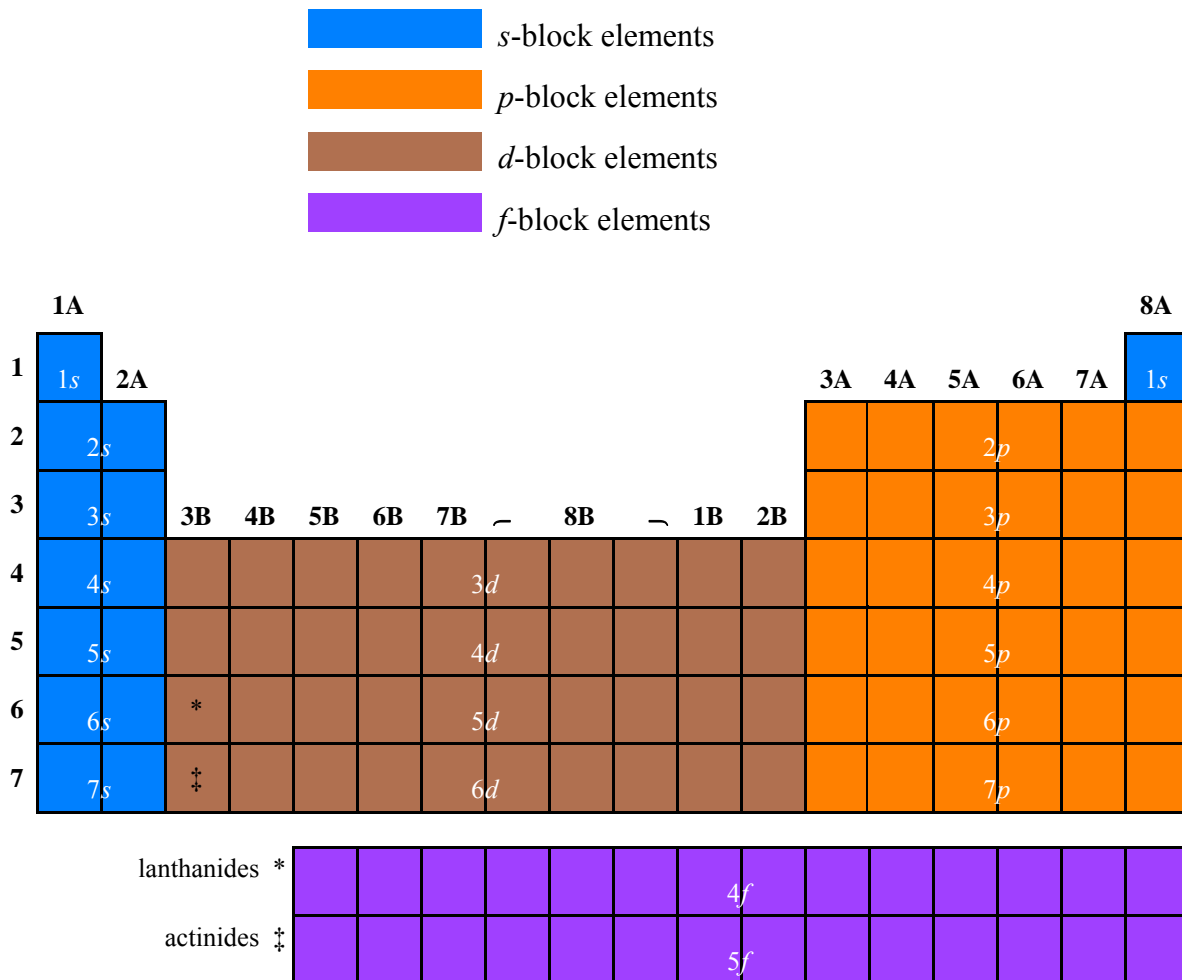
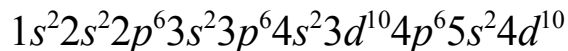

Figure 7.11 Periodic Table showing sublevels being filled

Now fill each sublevel until you accommodate all 48 electrons. This results in the following electron configuration for cadmium.²



Again note that the sum of the superscripts in the electron configuration equals the total number of electrons present.

There are two other patterns that are particularly noteworthy. First, elements found in the same A group, for example, H, Li, Na, K in Group 1A or He, Ne, Ar, Kr in Group 8A, all have the same number of valence electrons, and the number of valence electrons for each atom is equal to the group number. This is a very useful general result. For example, all of the elements in Group 3A have three valence electrons. The fact that all elements in the same A group have the same number of valence electrons is the reason why the chemical properties of these elements are similar.

Second, for all elements the principal quantum number of the valence electrons is equal to the period number of the element. For example, since sulfur (S) is located in the third period, n for its valence shell is 3. This means that the valence electron configuration for any A group element will take the form of $ns^x np^y$ where n is the period number for the element and $x+y$ (the number of valence electrons) equals the group number of the element. Remember that the s sublevel fills with two electrons before the higher energy p sublevel.

Check for Understanding 7.4

Solutions

1. Write the electron configuration for an atom of bromine (Br).
2. Write the valence electron configuration for an atom of tin (Sn).

²There are some exceptions to the expected filling pattern but these will not be considered in this course.

Now let us see how information about the electron configuration of atoms can be used to explain one of the important chemical properties noted in the text. This application of fundamental concepts is challenging, but it will help you develop both insight and understanding.

Property: Elements classified as metals tend to lose electrons and form cations while nonmetallic elements tend to gain electrons and form anions.

Explanation

In discussing how electron configurations can provide an explanation for the property noted above, it is helpful for us to remember one important implication of Coulomb's law: the larger the opposite charges the greater the electrostatic attraction. Metals tend to lose electrons because the energy needed to remove the least tightly bound electrons, the valence electrons, from metal atoms is generally less than that for nonmetal atoms. The energy needed to remove a valence electron depends on the strength of the electrostatic force between the nucleus and the electron. You might think that the higher the atomic number (Z), the higher the positive charge in the nucleus and the higher this electrostatic attraction. However, what is important is the **effective nuclear charge** (Z_{eff}) which is the actual positive charge "felt" by the valence electrons. Z_{eff} is not the same as Z because valence electrons are "shielded" from the nucleus by electrons occupying lower energy levels. The negative charge clouds of these lower energy electrons occupy space between the nucleus and the valence electrons. The lower energy electron clouds actually serve to repel the valence electrons and this reduces the attraction between the nucleus and the valence electrons. You can get an approximate value for Z_{eff} from the simple relationship:

$$Z_{\text{eff}} = Z - \sigma$$

where σ is the shielding factor. A useful estimate of σ is obtained by counting the number of lower energy (smaller n value) electrons.³ The higher the value for Z_{eff} the

³Electrons with the same n but in a lower energy sublevel can also shield higher energy electrons but this effect is less significant.

stronger the nuclear attraction for the electron and the more energy needed to remove it.

Compare the situation for a sodium atom (a metal with $Z=11$) and a chlorine atom (a nonmetal with $Z=17$). The electron configuration for sodium is $1s^22s^22p^63s^1$. Since there are 10 electrons in lower principal energy levels than the single $3s$ valence electron, $\sigma \sim 10$ and $Z_{\text{eff}} \sim 11 - 10 = 1$. Chlorine has an electron configuration of $1s^22s^22p^63s^23p^5$. There are also 10 lower energy electrons, so $\sigma \sim 10$ and $Z_{\text{eff}} \sim 17 - 10 = 7$. This indicates that the chlorine nucleus has a much stronger attraction for the valence electrons than the sodium nucleus. This weaker attraction of the nucleus for the $3s$ valence electron in a sodium atom means less energy is needed to remove it. Because of the smaller amount of energy needed to remove an electron from a sodium atom than a chlorine atom, sodium will tend to lose electrons more easily than chlorine.

In order to see that Z_{eff} is not simply proportional to Z , estimate Z_{eff} for the valence electrons in a calcium atom ($Z=20$). The electron configuration for calcium is $1s^22s^22p^63s^23p^64s^2$. Since there are 18 electrons in lower principal energy levels than the $4s$ valence electrons, $\sigma \sim 18$ and $Z_{\text{eff}} \sim 20 - 18 = 2$. Thus, it should require less energy to remove an electron from a calcium atom than for chlorine even though calcium has a higher atomic number. You can also correctly predict from this result that it takes more energy to remove an electron from a calcium atom than from a sodium atom.

Chlorine atoms tend to gain electrons more than sodium or calcium atoms for this same reason; Z_{eff} for the valence electron energy level is greater, so a stronger attraction exists between the added electron and the nucleus for chlorine compared to sodium or calcium. Adding an electron to an atom is just the reverse of removing an electron, so you expect energy to be released when an electron is gained. Since chlorine has a stronger attraction for an electron added to its valence energy level than does sodium or calcium, more energy will be released when an electron is gained by chlorine. This energy release, in fact, can be used to remove an electron from a metal atom so that it can be added to chlorine.

This example illustrates how knowledge of electron configurations can be used to explain basic chemical properties. Similar connections to electronic structure can be made in order to explain why A group metals tend to form cations with a charge equal to the group number, or why oxygen atoms have a greater attraction for shared electrons than do hydrogen atoms. These correlations and many others will be discussed in subsequent chemistry classes. Our example also illustrates a very important pattern you will observe throughout chemistry: the atomic/electronic structure of a substance is responsible for its properties. By understanding such connections, chemists are able to create new materials with remarkable properties. These new materials have the potential to improve the quality of life by solving problems associated with the environment, medicine, technology, farming, consumer product safety and many other areas. This is why there truly is “better living through chemistry”.

Chapter 7 Keywords**Glossary**

electromagnetic radiation	frequency	sublevel
electromagnetic spectrum	hertz	orbital
microwave radiation	speed of light	parallel spins
infrared radiation	photoelectric effect	ground state
visible light	photon	excited state
ultraviolet radiation	Planck's constant	electron configuration
x-rays	wave-particle duality	valence electron
wavelength	atomic emission spectrum	core electrons
radio waves	line spectrum	lanthanides
gamma radiation	quantized	actinides
cycle	principal quantum number	effective nuclear charge
amplitude	quantum mechanics	

Supplementary Chapter 7 Check for Understanding questions**Chapter 7 Exercises****Answers**

(You may use a basic periodic table as needed.)

- Draw a graph that qualitatively represents each of the following.
 - a plot of frequency versus wavelength
 - a plot of photon energy versus frequency
 - a plot of photon energy versus wavelength
- The distance between two successive peaks in a wave is called the:
 - frequency
 - speed
 - amplitude
 - none of these

3. Electromagnetic radiation that has more energy per photon than visible light is:
- A. infrared light.
 - B. microwaves.
 - C. ultraviolet radiation.
 - D. all of the above.
 - E. both A and C.
4. Which of the following colors of visible light has the most energy per photon?
- A. blue
 - B. yellow
 - C. orange
 - D. violet
 - E. green
5. The larger the value of the principal quantum number n :
- A. the higher the potential energy of the electron.
 - B. the closer the electron is to the nucleus on the average.
 - C. the more tightly bound the electron is to the nucleus.
 - D. then all of the above are true.
6. The line spectrum for hydrogen gas is shown below.



These four emission lines result from electrons moving from the $n = 3, 4, 5$ and 6 levels to the $n = 2$ level. Identify which transition is associated with each color. Briefly explain your choices.

7. In your own words explain what wave-particle duality means.
8. Imagine scaling a wall with either a ladder or a rope hanging over the edge. As you climb up the wall is your height above the ground quantized using either the rope or the ladder? Explain.
9. How many orbitals are associated with each of the following?
- a) *s* sublevel b) *p* sublevel c) *d* sublevel
10. What is the maximum number of electrons allowed in each of the following?
- a) a *p* orbital b) a *d* sublevel c) the $n = 4$ energy level
11. Write the ground state electron configuration for each of the following elements.
- a) aluminum b) rubidium c) barium d) nickel
12. Identify the element that has the ground state electron configuration that matches each of the following.
- a) $1s^2 2s^2 2p^6 3s^2 3p^4$ b) $1s^2 2s^2 2p^6 3s^2 3p^6 4s^2 3d^5$ c) $1s^2 2s^2 2p^6 3s^2 3p^6 4s^1$
13. Write the valence electron configuration for each of the following elements.
- a) iodine b) argon c) titanium d) magnesium
14. Identify the element that has the valence electron configuration that matches each of the following.
- a) $2s^2 2p^1$ b) $6s^2 6p^2$ c) $3s^2 3p^3$

15. Identify the element with the lowest atomic number that satisfies each of the following.
- a) has a completely filled set of p orbitals
 - b) has two d orbital electrons
 - c) has electrons in four different sublevels
 - d) has an f orbital electron
 - e) has 6 valence electrons
16. The Group 2A elements have similar chemical properties because:
- A. their atoms are all very similar in size.
 - B. their atoms have similar valence electron configurations.
 - C. their atoms have similar nuclear charges.
 - D. all of the above are true.
17. How does the effective nuclear charge for a valence electron in a carbon atom compare to that for a valence electron in a magnesium atom?

Chapter 7**Check for Understanding 7.1**

1. What is the wavelength in meters of a radio wave having a frequency of 88.5 MHz?

Answer: 3.4 m/cycle (or 3.4 m)

Solution

What we know: MHz frequency; relationship between frequency and wavelength

Desired answer: m/cycle

The solution map for this calculation is:

$$\text{MHz} \rightarrow \text{Hz(cycles/s)} \rightarrow \text{m/cycle}$$

The conversion factor needed in the first step is that between *MHZ* and *Hz* in the form $\frac{10^6 \text{ Hz}}{1 \text{ MHz}}$.

Applying this yields:

$$88.5 \text{ MHz} \times \frac{10^6 \text{ Hz}}{1 \text{ MHz}} = 8.85 \times 10^7 \text{ Hz} = 8.85 \times 10^7 \text{ cycles/s}$$

The conversion factor needed in the second step is the relationship between frequency and wavelength. Recall that $c = 3.0 \times 10^8 \text{ m/s}$.

$$\lambda = \frac{c}{\nu} = \frac{3.0 \times 10^8 \text{ m/s}}{8.85 \times 10^7 \text{ cycles/s}} = 3.4 \text{ m/cycle}$$

2. What is the frequency of green light having a wavelength of 510 nm?

Answer: 5.9×10^{14} cycles/s

Solution

What we know: nm wavelength; relationship between frequency and wavelength

Desired answer: cycles/s

The solution map for this calculation is:

$$\text{nm/cycle} \rightarrow \text{m/cycle} \rightarrow \text{cycles/s}$$

The conversion factor needed in the first step is that between *nm* and *m* in the form

$$\frac{10^{-9} \text{ m}}{1 \text{ nm}}$$

Applying this yields:

$$\frac{510 \cancel{\text{nm}}}{\text{cycle}} \times \frac{10^{-9} \text{ m}}{1 \cancel{\text{nm}}} = \frac{5.1 \times 10^{-7} \text{ m}}{\text{cycle}}$$

The conversion factor needed in the second step is the relationship between wavelength and frequency. Recall that $c = 3.0 \times 10^8 \text{ m/s}$.

$$\nu = \frac{c}{\lambda} = \frac{3.0 \times 10^8 \cancel{\text{m}}/\text{s}}{5.1 \times 10^{-7} \cancel{\text{m}}/\text{cycle}} = 5.9 \times 10^{14} \text{ cycles/s}$$

Check for Understanding 7.2

- What is the ground state electron configuration for an atom of each of the following.
 - C
 - Fe

Answers: a) $1s^2 2s^2 2p^2$
 b) $1s^2 2s^2 2p^6 3s^2 3p^6 4s^2 3d^6$

Solutions

What we know: number of electrons in each atom; order of filling the electron energy levels

Desired answer: ground state electron configuration for each atom

- From the periodic table you can find the atomic number for carbon ($Z=6$). This represents the number of electrons that must be accounted for in the electron configuration. From the energy level diagram in Figure 7.10, the electron energy levels go in the order $1s, 2s, 2p, 3s, 3p, 4s, 3d\dots$ Start filling the orbitals until all 6 electrons are accounted for; remember each orbital can have a maximum of two electrons. The correct electron configuration is $1s^2 2s^2 2p^2$.

- b) From the periodic table you can find the atomic number for iron ($Z=26$). This represents the number of electrons that must be accounted for in the electron configuration. From the energy level diagram in Figure 7.10, the electron energy levels go in the order $1s, 2s, 2p, 3s, 3p, 4s, 3d...$ Start filling the orbitals until all 26 electrons are accounted for; remember each orbital can have a maximum of two electrons. The correct electron configuration is $1s^2 2s^2 2p^6 3s^2 3p^6 4s^2 3d^6$.

Check for Understanding 7.3

1. How many valence electrons does an atom of each of the following elements have?
- a) Cl b) Ni

Answers: a) 7
 b) 2

Solutions

- a) Since chlorine (Cl) is from Group 7A it has seven valence electrons.
- b) Since nickel (Ni) is a B group element, you must determine its electron configuration to decide on how many valence electrons there are. Nickel has 28 electrons. Start with hydrogen and work across from left to right and down the periodic table until you get to Ni. In the process you will put electrons into the following sequence of orbitals.



Now fill each sublevel until you accommodate all 28 electrons. This results in the following electron configuration for nickel.



The highest occupied electron energy level is $n = 4$, thus there are 2 valence electrons in a nickel atom.

Check for Understanding 7.4

1. Write the electron configuration for an atom of bromine (Br).

Answer: $1s^2 2s^2 2p^6 3s^2 3p^6 4s^2 3d^{10} 4p^5$

Solution

Bromine has 35 electrons. Start with hydrogen and work across from left to right and down the periodic table until you get to bromine. In the process you will put electrons into the following sequence of orbitals.



Now fill each sublevel until you accommodate all 35 electrons. This results in the following electron configuration for Br.

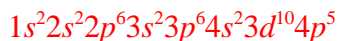

2. Write the valence electron configuration for an atom of tin (Sn).

Answer: $5s^25p^2$

Solution

Since tin is in Group 4A and period 5 it has 4 valence electrons that occupy the $n = 5$ energy level. This means the valence electron configuration will take the form $5s^x5p^y$. Two of the electrons will fill the s sublevel and the remaining 2 electrons will fill the p sublevel so the valence electron configuration of tin is $5s^25p^2$.

Chapter 7

1. a)

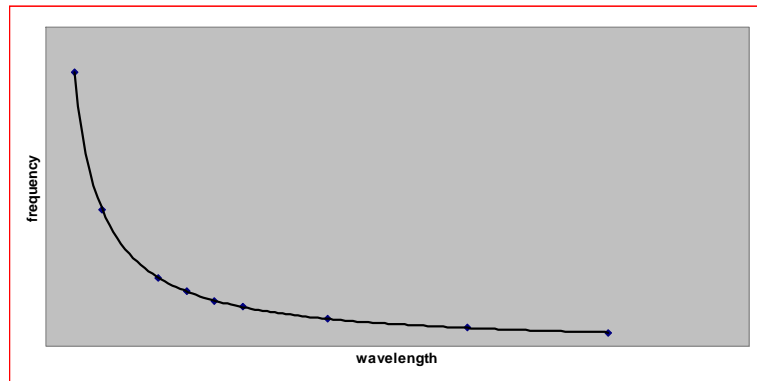

b)

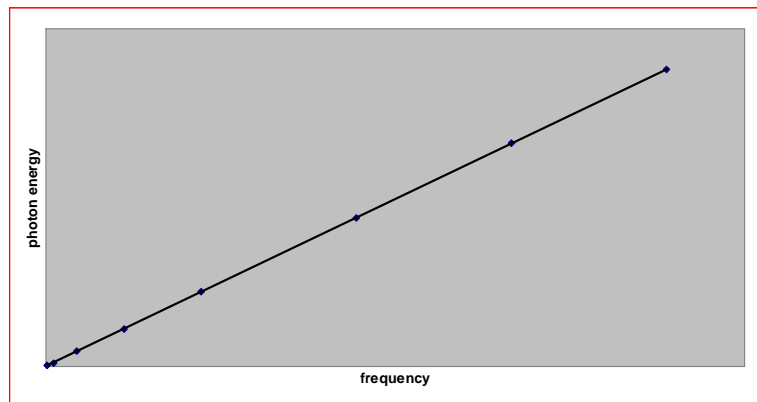

c)

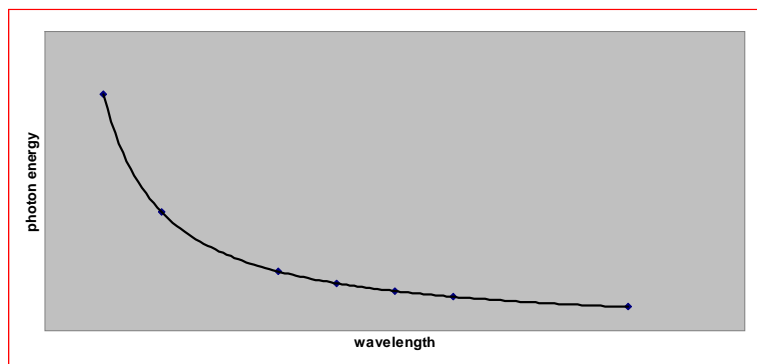

2. D

3. C

4. D

5. A

6. red line $n = 3 \rightarrow n = 2$

teal line $n = 4 \rightarrow n = 2$

blue line $n = 5 \rightarrow n = 2$

violet line $n = 6 \rightarrow n = 2$

The red line (656 nm) represents the longest wavelength radiation and hence the smallest amount of photon energy so the transition takes place between the $n = 2$ and the next highest level ($n = 3$).

The violet line (410 nm) represents the shortest wavelength radiation and hence the largest amount of photon energy so the transition takes place between the $n = 2$ and the highest excited ($n = 6$).

The teal line (486 nm) represents radiation with a wavelength slightly shorter than that for the red line and hence a slightly larger amount of photon energy so the transition takes place between the $n = 2$ and the $n = 4$ levels.

The blue line (434 nm) represents radiation with a wavelength slightly longer than that for the violet line and hence a slightly smaller amount of photon energy so the transition takes place between the $n = 2$ and the $n = 5$ levels.

8. Your height above the ground is quantized in the case of the ladder because you can only position yourself at specific heights corresponding to the rungs of the ladder. Your height above the ground is not quantized in the case of the rope because you can position yourself at essentially any height as you pull yourself up the rope.

9. a) 1

b) 3

c) 5

10. a) 2
b) 10
c) 32
11. a) $1s^2 2s^2 2p^6 3s^2 3p^1$
b) $1s^2 2s^2 2p^6 3s^2 3p^6 4s^2 3d^{10} 4p^6 5s^1$
c) $1s^2 2s^2 2p^6 3s^2 3p^6 4s^2 3d^{10} 4p^6 5s^2 4d^{10} 5p^6 6s^2$
d) $1s^2 2s^2 2p^6 3s^2 3p^6 4s^2 3d^8$
12. a) sulfur (S)
b) manganese (Mn)
c) potassium (K)
13. a) $5s^2 5p^5$
b) $3s^2 3p^6$
c) $4s^2$
d) $3s^2$
14. a) boron (B)
b) lead (Pb)
c) phosphorus (P)

15. a) neon (Ne)
 b) titanium (Ti)
 c) sodium (Na)
 d) cerium (Ce)
 e) oxygen (O)
16. **B**
17. $Z_{\text{eff}} \sim 4$ for a valence electron in carbon
 $Z_{\text{eff}} \sim 2$ for a valence electron in magnesium